

UNIT MAINTENANCE MANUAL
INCLUDING REPAIR PARTS AND SPECIAL TOOLS LIST

MOUNTING KIT, SMOKE GENERATOR: M284
(1040-01-249-0272)

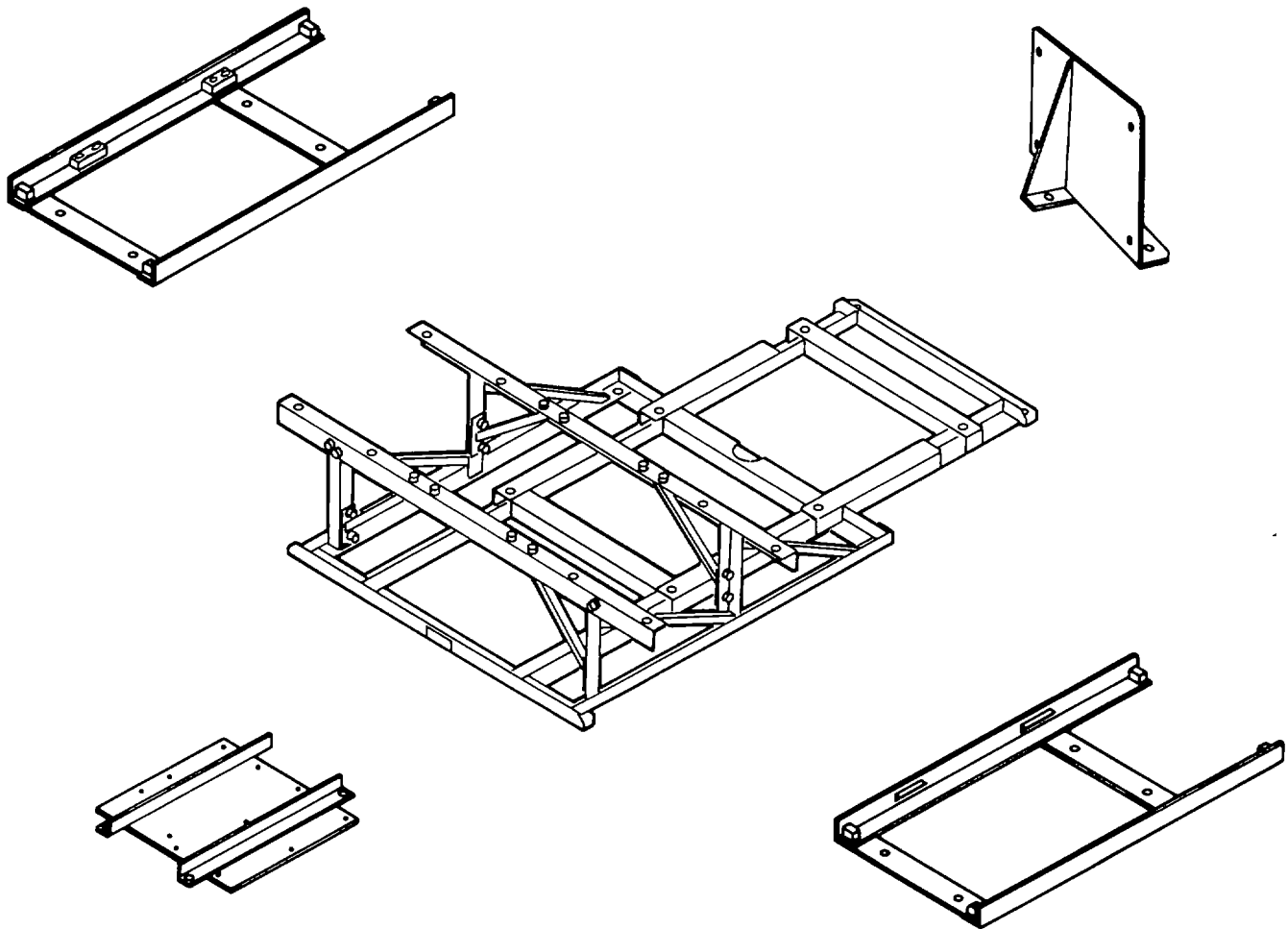

DISTRIBUTION STATEMENT A. Approved for public release; distribution is unlimited.

HEADQUARTERS, DEPARTMENT OF THE ARMY

OCTOBER 1989

Change

No. 1

HEADQUARTERS
DEPARTMENT OF THE ARMY
Washington, DC, 24 April 1990

**Unit Maintenance Manual
Including Repair Parts and Special Tools List**

**MOUNTING KIT, SMOKE GENERATOR: M284
(1040-01-249-0272)**

This change adds warnings to prevent a potential safety hazard.

TM 3-1040-280-20&P, 18 October 1989, is changed as follows:

1. Remove old pages and insert new pages as indicated below. New or changed material is indicated by a vertical bar in the margin of the page.

Remove Pages

a/(b blank)
2-5 thru 2-8
2-45 thru 2-48
2-53 and 2-54

Insert Pages

a/(b blank)
2-5 thru 2-8
2-45 thru 2-48
2-53 and 2-54

2. File this change sheet in front of the publication for reference purposes.

By Order of the Secretary of the Army:

Official:
WILLIAM J. MEEHAN
Brigadier General, United States Army
The Adjutant General

CARL E. VUONO
General, United States Army
Chief of Staff

Distribution:

To be distributed in accordance with DA Form 12-28, requirements for TM 3-1040-280-20&P.

WARNINGS

Dry cleaning solvent is flammable and toxic. Keep it away from heat or open flames. Use in well ventilated area. Avoid breathing vapors. Failure to observe precautions may result in injury to personnel or damage to equipment.

Always wear eye protection when drilling or when working under vehicle. Eye injury may result if metal chips or falling dirt get into eyes.

Use a brush when cleaning up metal chips to avoid injury to hands.

Surfaces covered with fog oil will become slippery and may cause personnel injury due to falls. Clean up all spillage or leakage of fog oil. Avoid spilling fog oil. Do not drain fog oil near open flames or while smoking.

Gasoline is very flammable. Do not allow open flames, sparks, or smoking in the area while performing maintenance.

Air compressor tank is pressurized to 63 pounds per square inch gage (psig). Bleed air from tank before attempting maintenance or disconnecting hoses.

Metal objects such as rings or tools can short circuit the battery and cause severe burns to personnel. Remove all jewelry before starting work. Do not allow tools to contact the vehicle when removing or installing battery cables.

Components of the M157 smoke generator set and M284 mounting kit are heavy. To prevent personnel injury, use a hoist or request assistance when lifting components.

FIRST AID

For first aid information, refer to FM 21-11 (TEST)

Change 1 a/(b blank)

**CHAPTER 1
INTRODUCTION**

Section I. GENERAL INFORMATION

1-1. SCOPE.

- a. Type of Manual. Unit/Maintenance Manual Including Repair Parts and Special Tools List.
- b. Model Number and Equipment Name. M284 smoke generator mounting kit.
- c. Purpose of Equipment. MountstheM157 smoke generator set on the M998 or M1037cargo/troop carrier.

1-2. MAINTENANCE FORMS, RECORDS, AND REPORTS.

Department of the Army forms and procedures used for equipment maintenance will be those prescribed by DA PAM 738-750, The Army Maintenance Management System (TAMMS), as contained in Maintenance Management Update.

1-3. DESTRUCTION OF MATERIEL TO PREVENT ENEMY USE.

Destroy mounting kit components by mechanical means, demolition, or gunfire as described in TM 43-0002-31.

1-4. PREPARATION FOR STORAGE OR SHIPMENT.

Refer to chapter 2, section V for administrative storage instructions.

1-5. OFFICIAL NOMENCLATURE, NAMES, AND DESIGNATIONS.

This listing includes nomenclature cross-references used in this manual.

Common Name	Official Nomenclature
Mounting kit	Mounting Kit, Smoke Generator: M284
Fog oil tank assembly M998 or M1037 cargo/troop carrier	Tank Unit, Liquid Dispenser
Smoke generator set	Truck, Utility: Cargo/Troop Carrier, 1-1/4 Ton, 4 X 4, M998 or M1037 Generator Set, Smoke, Mechanical: Pulse Jet, M157
Control panel assembly	Control-Indicator

1-6. REPORTING EQUIPMENT IMPROVEMENT RECOMMENDATIONS (EIR's).

If your mounting kit needs improvement, let us know. Send us an EIR. You, the user, are the only one who can tell us what you don't like about your equipment. Let us know why you don't like the design or performance. Tell us why a procedure is hard to perform. Put it on an SF 368 (Product Quality Deficiency Report). Mail it to us at Commander, US Army Armament, Munitions and Chemical Command, ATTN: AMSMC-QAD (R), Rock Island, IL 61299-6000. We'll send you a reply.

Section II. EQUIPMENT DESCRIPTION AND DATA

1-7. EQUIPMENT CHARACTERISTICS, CAPABILITIES AND FEATURES.

- a. Transports smoke generators
- b. Provides a mobile operating platform
- c. Open-air design allows easy maintenance of equipment
- d. Provides storage of fuel and fog oil for smoke generator operation

1-8. LOCATION AND DESCRIPTION OF MAJOR COMPONENTS.

- A CONTROL PANEL MOUNTING BRACKET. Rigid steel bracket screwed into the ribbed floor of the vehicle cargo bed and used to mount the Smoke Generator Control Panel on the vehicle. Angles the Control Panel toward the companion seat to allow easy access to switches, controls and indicators for operating and monitoring each smoke generator, the fog oil pump, and the air compressor.
- B FUEL CAN BRACKETS. Used to mount standard 5-gallon military gasoline cans on support brackets provided in mounting kit. One mounted at each rear seat location. Special lid assemblies furnished with mounting kit contain hoses for fuel supply and return connections to smoke generator.
- C FIRE EXTINGUISHER. Five pound dry chemical fire extinguisher. One mounted on each rear wheelhouse.
- D GENERATOR BRACKET ASSEMBLIES. Rigid brackets fabricated from angle iron which bolt to frame assembly. Wedge-type clamps secure smoke generators in brackets.
- E AIR COMPRESSOR MOUNTING BRACKET. Rigid steel bracket fabricated from sheet steel and angle iron. Used to mount the air compressor assembly onto the frame assembly.
- F FRAME ASSEMBLY. Rigid frame fabricated from angle iron and square tubular sections. Frame is bolted to the vehicle cargo bed using existing cargo tie down bolt holes.

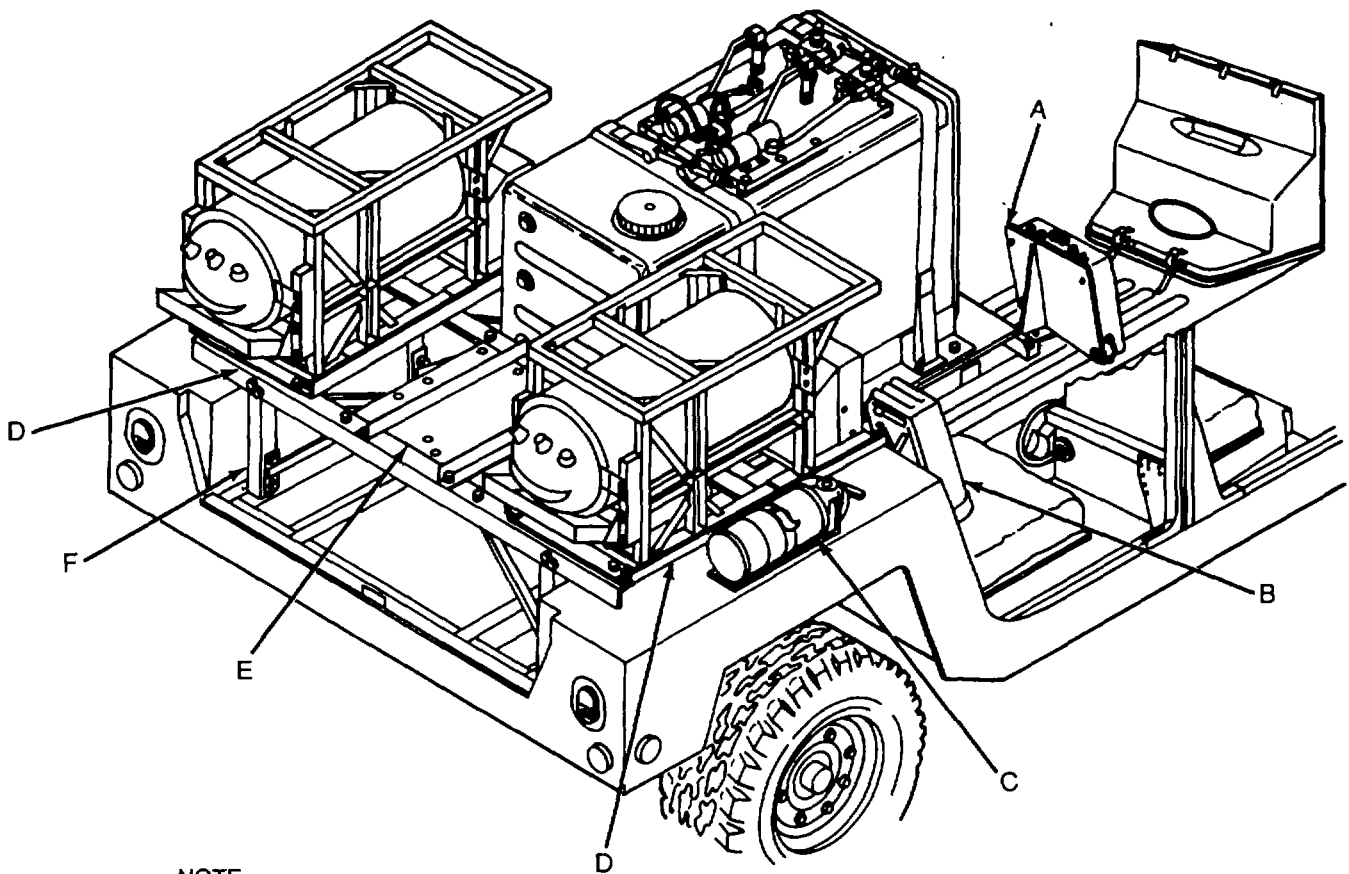

NOTE
TAILGATE OMITTED FROM VEHICLE
FOR CLARITY THROUGHOUT MANUAL.

MAJOR COMPONENTS

1-9. LOCATION AND CONTENT OF IDENTIFICATION PLATES.

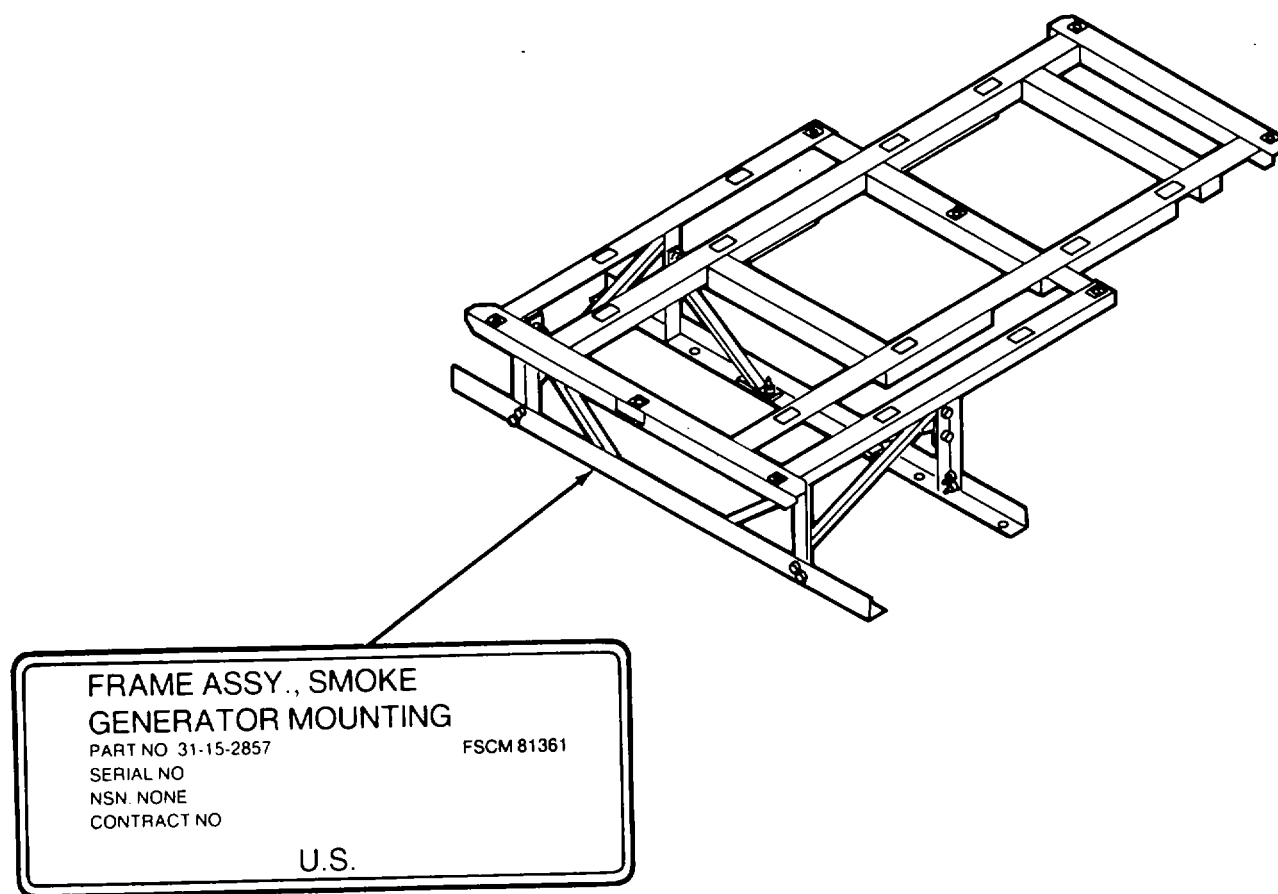

1-10. EQUIPMENT DATA. The following lists equipment data for the frame assembly only.

	(Uncrated)	(Crated)☆
Length	86.75 in.	93.48 in.
Width	64.50 in.	65.52 in.
Height	17.00 in.	26.64 in.
Weight	304 lb	711 lb

*Includes miscellaneous mounting hardware.

**CHAPTER 2
MAINTENANCE INSTRUCTIONS**

Section I. REPAIR PARTS; SPECIAL TOOLS; TEST, MEASUREMENT, AND DIAGNOSTIC EQUIPMENT (TMDE); AND SUPPORT EQUIPMENT

- 2-1. COMMON TOOLS AND EQUIPMENT.** For authorized common tools and equipment refer to the Modified Table of Organization and Equipment (MTOE) assigned to your unit.
- 2-2. SPECIAL TOOLS, TMDE, AND SUPPORT EQUIPMENT.** Refer to the Maintenance Allocation Chart (app B) for support equipment.
- 2-3. REPAIR PARTS.** Repair parts are listed and illustrated in appendix C of this manual.

Section II. SERVICE UPON RECEIPT

- 2-4. CHECKING UNPACKED EQUIPMENT.**
 - a. Inspect the equipment for damage incurred during shipment. If the equipment has been damaged, report the damage on SF 364, Report of Discrepancy (ROD).
 - b. Check the equipment against the packing slip to see if the shipment is complete. Report all discrepancies in accordance with the instructions of DA PAM 738-750.
 - c. Check to see whether the equipment has been modified (DA PAM 25-30).

2-5. INSTALLATION INSTRUCTIONS

This task covers vehicle preparation and installation of the M284 mounting kit components.

INITIAL SETUP

Facilities and Equipment

- Shop area with overhead chain hoist or 5-ton wrecker
- M157 smoke generator set
- M998 or M1037 cargo/troop carrier
- M284 mounting kit
- Drain hose (fig E-1, app E)

Materials/Parts

- Plastic strip (item 6, app D)
- Tie down straps (item 10, app D)

Personnel Required

- One mechanic
- One assistant

Tools

- Automotive Shop Equipment
- SC 4910-95-CL-A74:
 - Portable drill -1/2-inch
 - Twist drills - 7/32, 9/32, 13/32, 3/16
 - Goggles
 - Torque wrench, 0-170 ft lbs
- Hole saw GGG-S-66
- Wrench, 1-7/16 in.

References

- TM 9-2320-280-20
- TM 3-1040-279-12&P

General Safety Instructions

Always wear eye protection when drilling or when working under vehicle. Eye injury may result if metal chips or falling dirt get into eyes.

2-5. INSTALLATION INSTRUCTIONS (CONT).

- a. Cargo/Troop Carrier.

VEHICLE PREPARATION

a. Cargo canvas top, bows, troop seats, fixed rear doors, rear seat backs, eight cargo tie down straps, shelter support assembly and bulk-head, if installed, must be removed and will not be reused with this kit. (Refer to TM 9-2320-280-20.)

- b. Clean cargo bed.

c. Fire extinguisher and bracket must be removed and will not be reused with this kit. (Refer to TM 9-2320-280-20.)

- b. Frame Assembly.

INSTALLATION

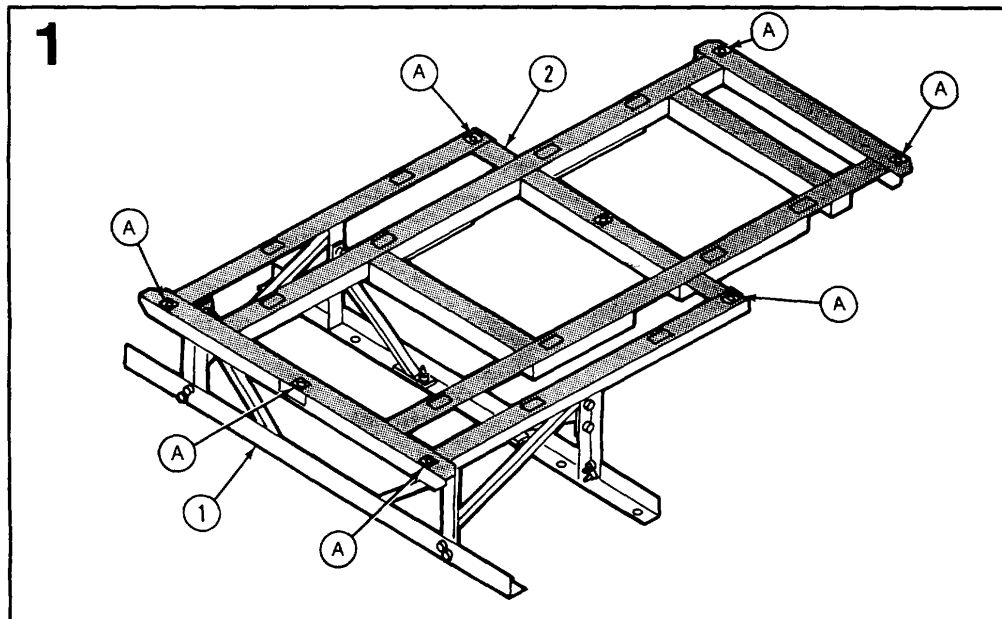

- a. Remove generator bracket assemblies if installed (p. 2-21)>
- b. Lean frame assembly (1) against a wall to
- c. Apply a layer of plastic strip (2) to frame assembly mounting surface. Cut out seven mounting holes (A) in plastic strip with knife.

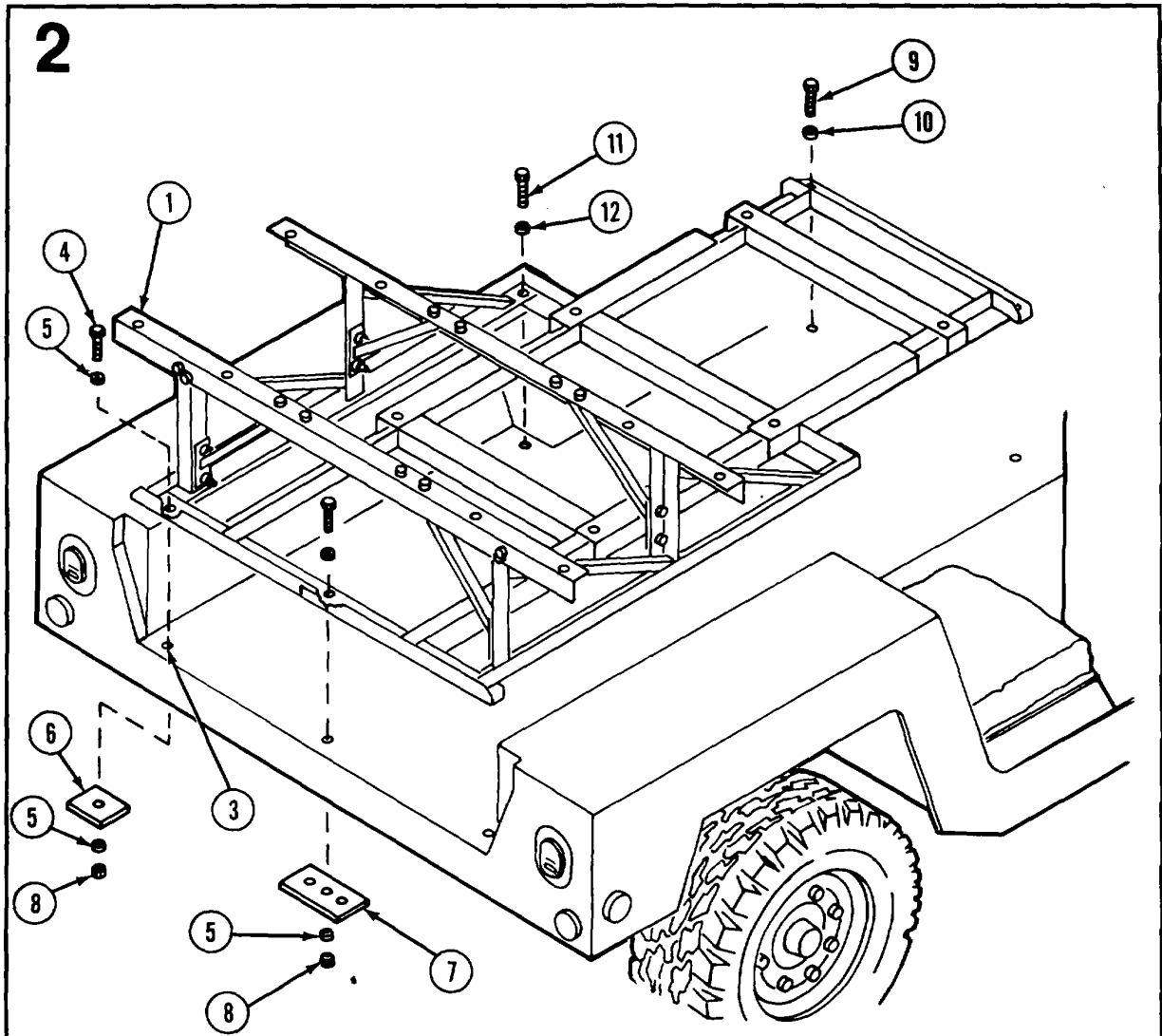

CAUTION

Do not slide frame assembly into cargo bed. Parts and/or equipment will be damaged.

- a. Using chain hoist or wrecker, position frame assembly (1) over mounting holes (3) in cargo bed.

NOTE

Screws (4) are longer than screws (9 and 11).

- b. Secure rear of frame assembly with three screws (4), six washers (5), two spacer plates (6), one spacer plate (7), and three nuts (8).
- c. Secure front of frame assembly with two screws (9) and two washers (10).
- d. Secure middle of frame assembly with two screws (11) and washers (12).
- e. Torque screws (9 and 11) to 75 foot-pounds.

2-5. INSTALLATION INSTRUCTIONS (CONT).

c. Fog Oil Tank Assembly.

INSTALLATION

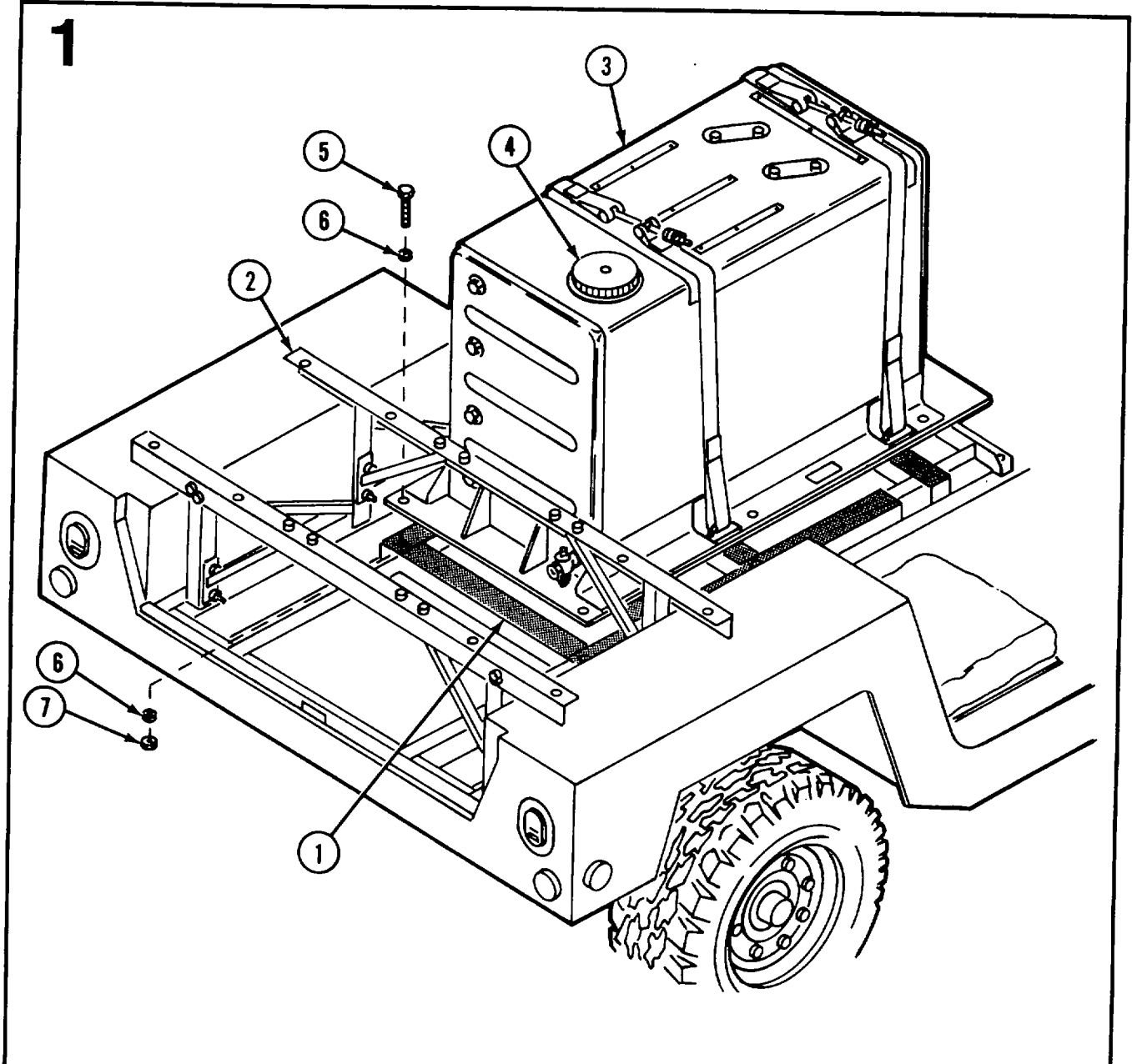

a. Apply a layer of plastic strip (1) to fog oil tank assembly mounting surface on frame assembly (2). Cut out six mounting holes in plastic strip with knife.

b. Using a chain hoist or wrecker, position fog oil tank assembly (3) on frame assembly with fuel cap (4) to rear of vehicle. Secure fog oil tank assembly with 6 screws (5), 12 washers (6), and 6 nuts (7).

2

- a. Remove existing adapter (8) and cap (9) from fog oil tank and install check valve (10).
- b. Remove protective plugs (11) from fog oil tank return and supply ports.
- d. Fog Oil Pump Assembly.

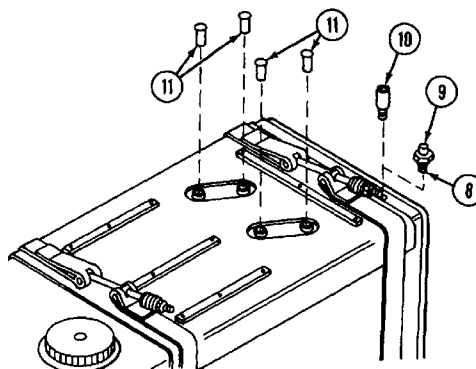

INSTALLATION

NOTE

Items 1, 8, 9, and 10 are components of the fog oil pump assembly. See TM 3-1040279-12&P.

- a. Install bushings (1) in the two fog oil tank return ports (2).
- b. Disconnect hose assemblies (3) from strainer assemblies (4) and remove strainer assemblies from fog oil pump assembly (5).
- c. Position fog oil pump assembly (5) on fog oil tank (6) with return tubes (7) in bushings (1). Tighten bushings (1).
- d. Install strainer assemblies (4) in fog oil tank (6).
- e. Connect hose assemblies (3) to strainer assemblies (4).
- f. Secure fog oil pump assembly (5) to fog oil tank assembly (6) with 12 screws (8), lockwashers (9), and washers (10).

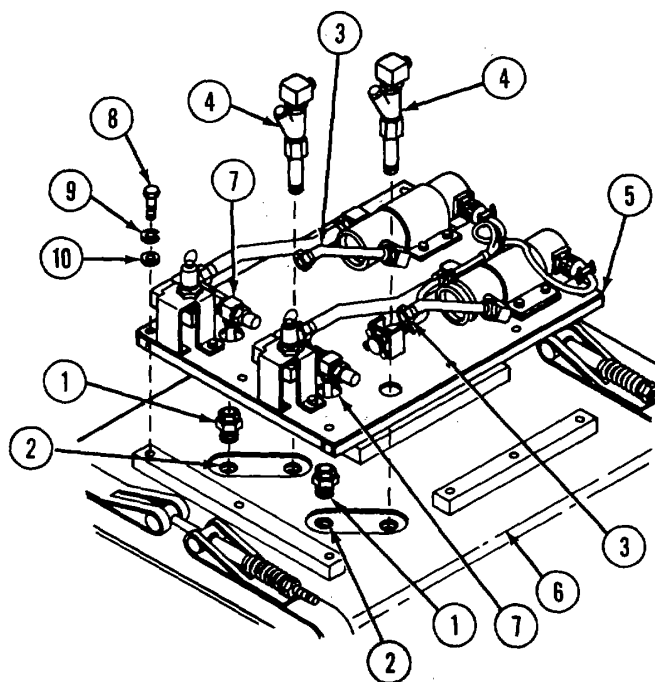

2-5. INSTALLATION INSTRUCTIONS (CONT).

- e. Air Compressor Assembly and Mounting Plate.

INSTALLATION

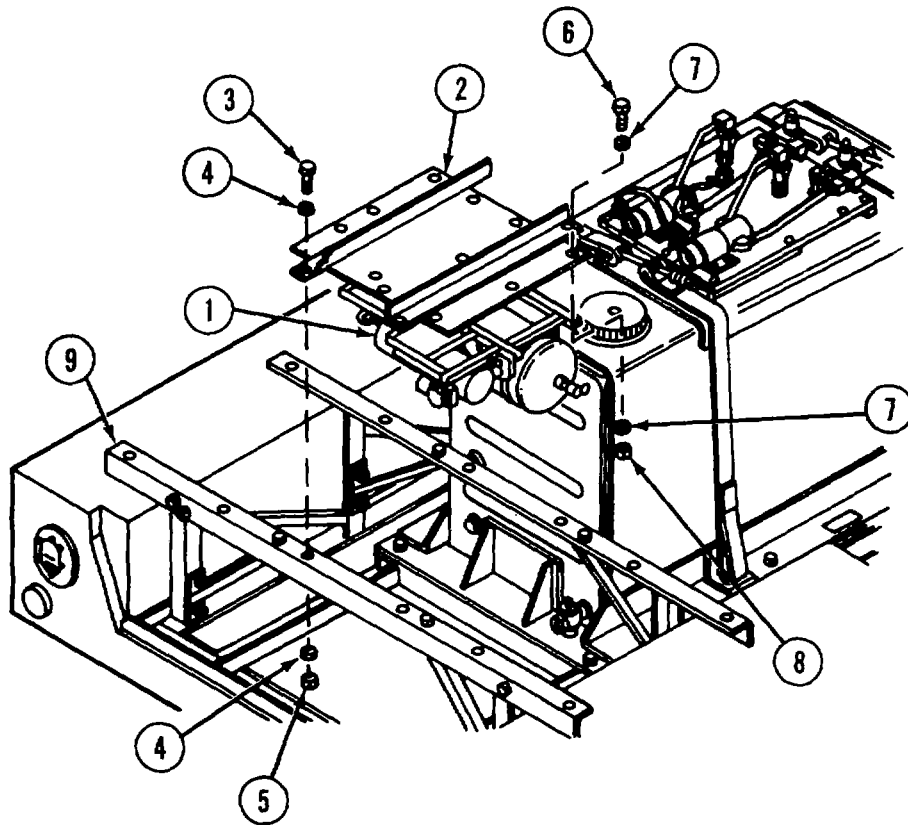

WARNING

Air compressor and mounting plate are heavy. To prevent personnel injury, use two people to lift.

- a. Attach air compressor assembly (1) to mounting plate (2) with 11 screws (3), 22 washers (4), and 11 nuts (5).
- b. Remove and retain four screws (6), eight washers (7) and four nuts (8) from generator support angles (9). Position mounting plate (2) over mounting holes in generator support angles (9) with air compressor tank to front of vehicle. Secure mounting plate to generator support angles with four screws (6), eight washers (7) and four nuts (8) retained from the generator support angles (9).

f. Generator and Bracket.

INSTALLATION

1

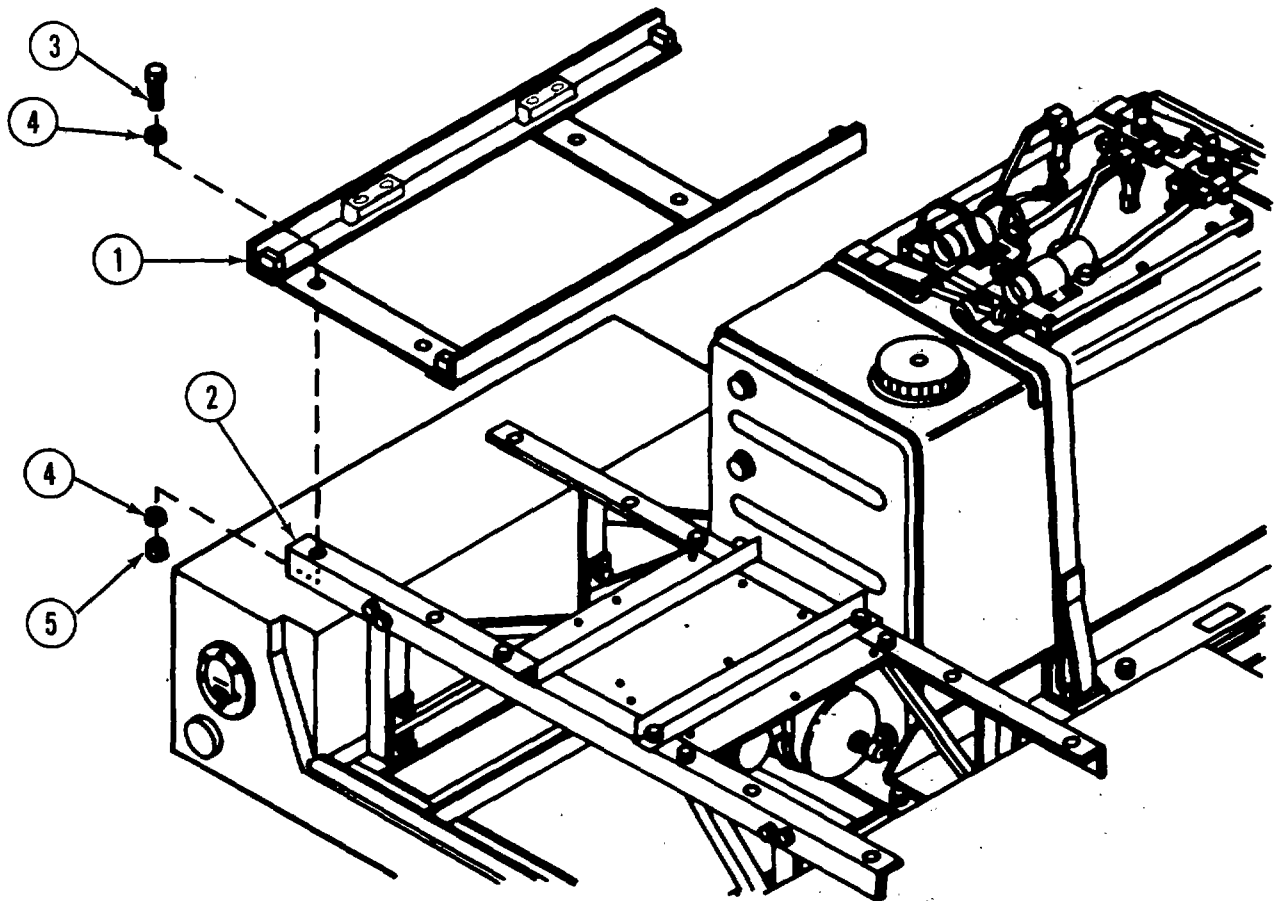

NOTE

Left side installation shown. Install right side bracket the same way.

Position generator brackets (1) over mounting holes in generator support angles (2). Secure generator brackets with 8 screws (3), 16 washers (4), and 8 nuts (5).

2-5. INSTALLATION INSTRUCTIONS (CONT).

f. Generator and Bracket (Cont).

INSTALLATION (CONT)

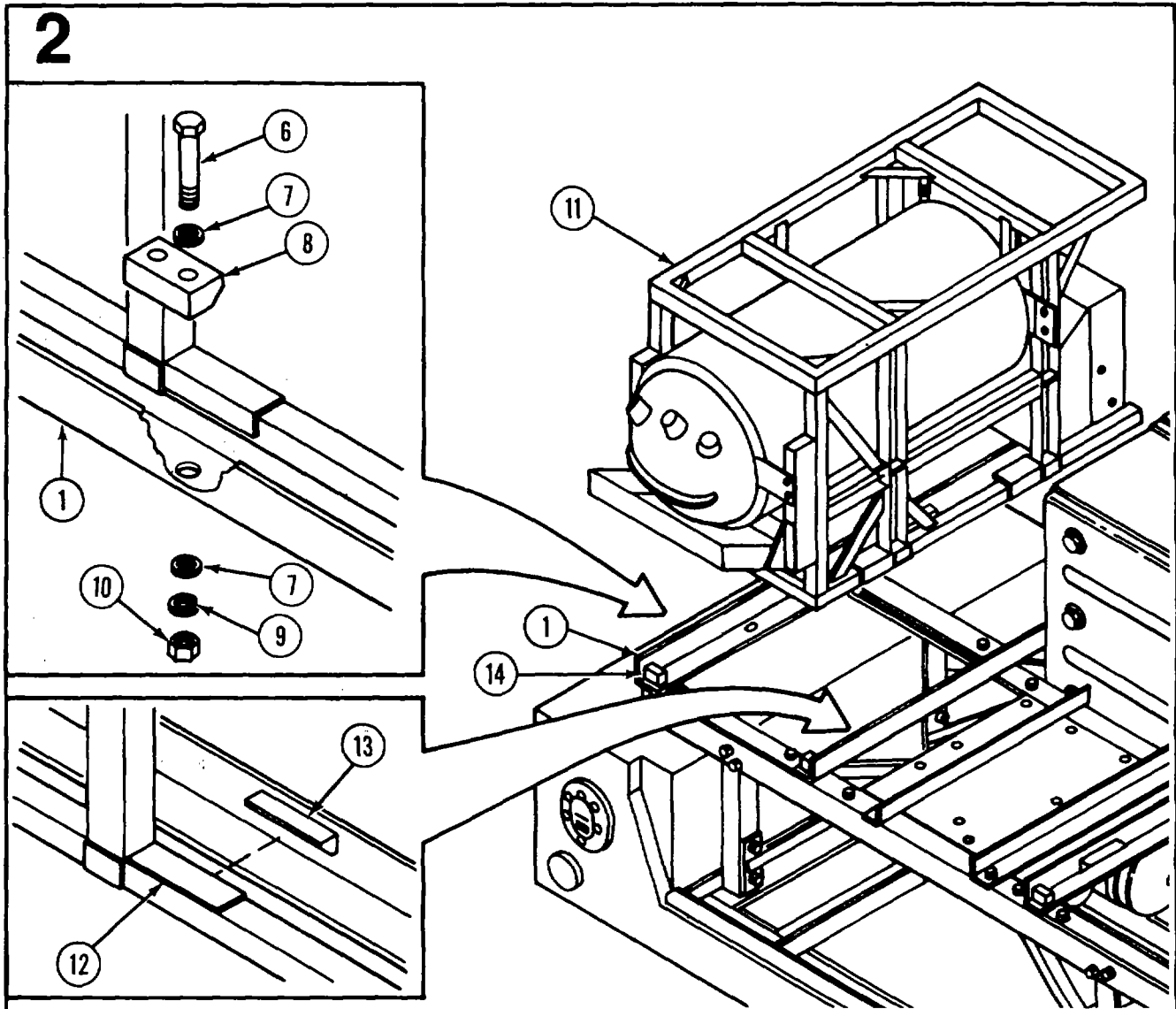

- a. Remove two screws (6), four washers (7), two connecting links (8), two lockwashers (9), and two nuts (10) from each generator bracket (1).

WARNING

Generator is heavy. To prevent personnel injury, use a hoist or four people to lift.

- b. Position smoke generator (11) in bracket (1) with generator frame (12) under lips (13) on bracket and against stop blocks (14).
- c. Secure smoke generator (11) in bracket (1) with two screws (6), four washers (7), two connecting links (8), two lockwashers (9) and two nuts (10).

g. Control Panel and Mounting Bracket.

INSTALLATION

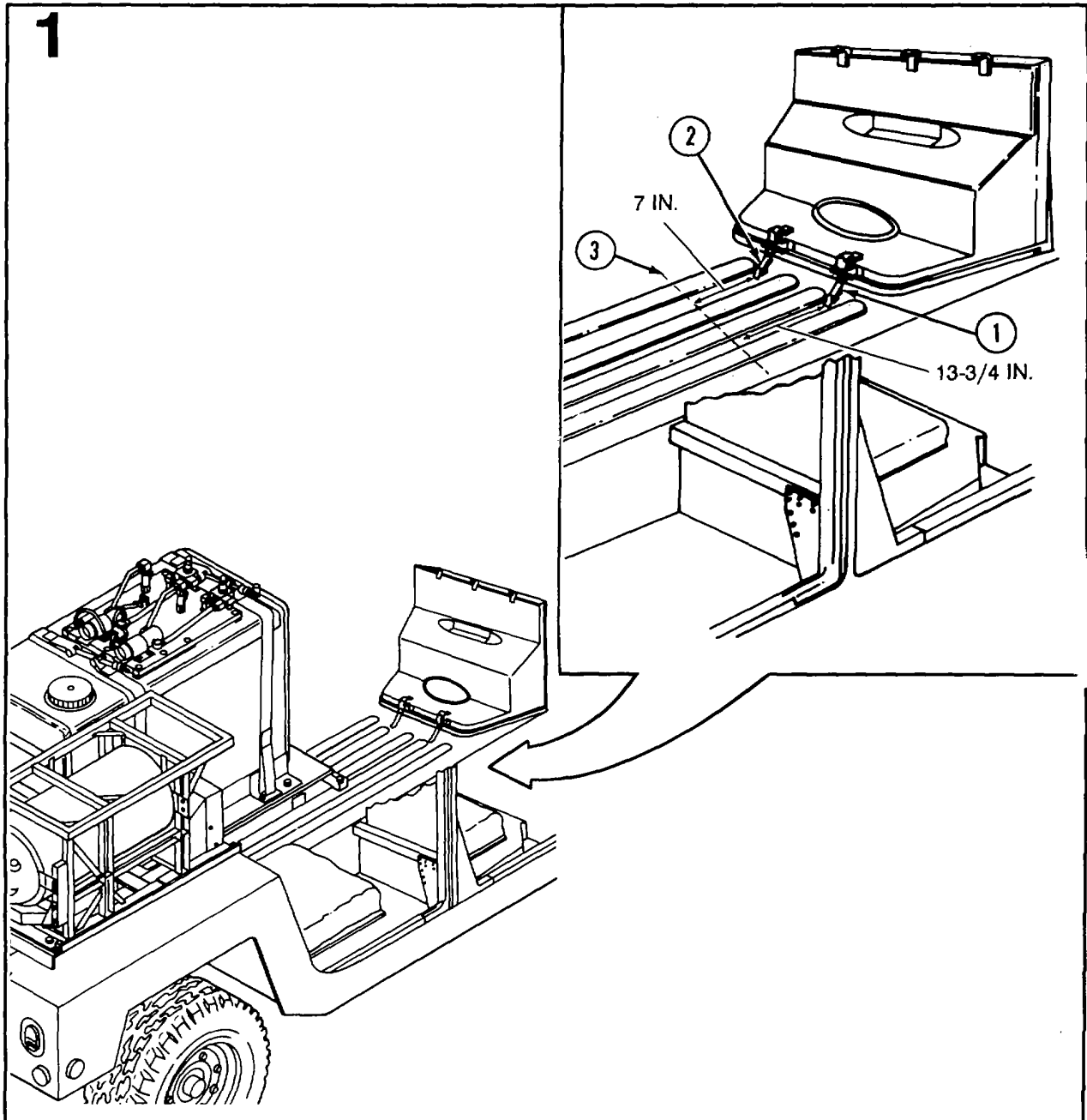

- a. Measure 13-3/4 inches from right rear edge of engine excess cover latch (1) and mark.
- b. Measure 7 inches from left rear edge of engine access cover latch (2) and mark.
- c. Scribe a diagonal line (3) connecting the two marks as shown.

2-5. INSTALLATION INSTRUCTIONS (CONT).

g. Control Panel and Mounting Bracket (Cont).

INSTALLATION (CONT)

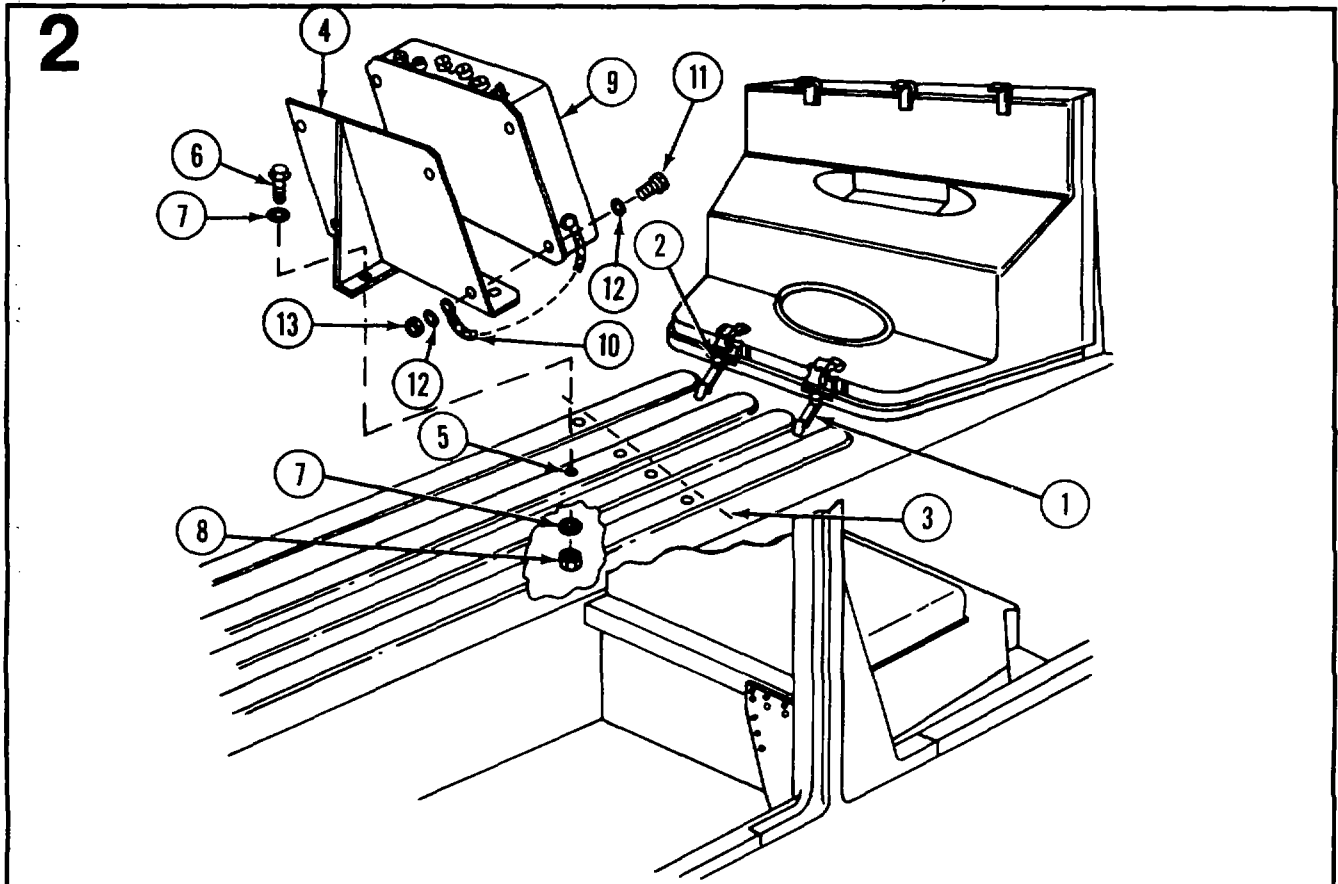

WARNING

Always wear eye protection when drilling. Eye injury may result if metal chips get into eyes.

Use a brush when cleaning up metal chips to avoid injury to hands.

- a. Position front edge of control panel mounting bracket (4) along scribed line (3) and center bracket holes on raised ribs. Using the bracket as a template, locate, mark, center punch and drill five 7/32-inch diameter pilot holes (5) in ribbed floor panel as shown.
- b. Enlarge pilot holes using a 13/32-inch drill.
- c. Secure control panel mounting bracket (4) to ribbed floor panel with 5 screws (6), 10 washers (7), and 5 nuts (8).
- d. Install control panel (9) and ground strap (10) on mounting bracket (4) with four screws (11), eight washers (12), and four nuts (13).
- e. Set circuit breaker CBI and all switches on control panel to OFF.

h. Fuel Can Base Plate and Bracket Assembly.

INSTALLATION

1

WARNING

Always wear eye protection when drilling. Eye injury may result if metal chips get into eyes.

Use a brush when cleaning up metal chips to avoid injury to hands.

NOTE

Left and right fuel can base plates are installed the same way at each rear seat location. Right side shown.

a. Use left and right fuel can base plates (1) as templates, position bracket reinforcement (2) between rivets (3), and locate, mark, center punch, and drill seven 7/32-inch diameter pilot holes (4) in each wheelhouse (5).

b. Enlarge pilot holes using a 1 3/32-inch drill.

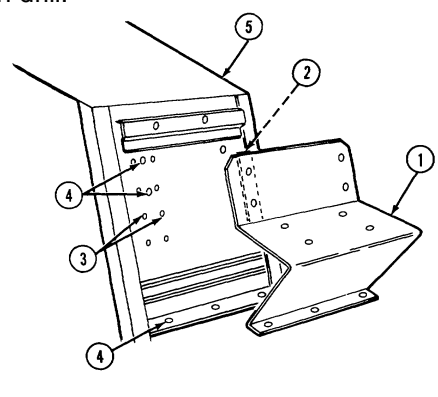

2

Install fuel can base plate (1) on each wheelhouse (5) with base plate doublers (6), 7 screws (7), 14 washers (8), and 7 nuts (9).

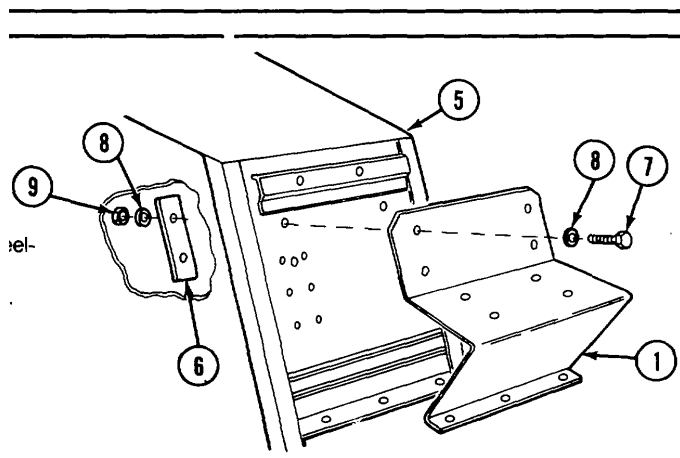

2-5. INSTALLATION INSTRUCTIONS (CONT).

h. Fuel Can Base Plate and Bracket Assembly (Cont).

INSTALLATION (CONT)

3

Install fuel can bracket assembly (10) on each base plate (1) with four screws (11), eight washers (12), and four nuts (13).

Position fuel cans on bracket assemblies (10) and secure with straps (14).

Install fuel lid assemblies on fuel cans (steps c and d, p 2-28).

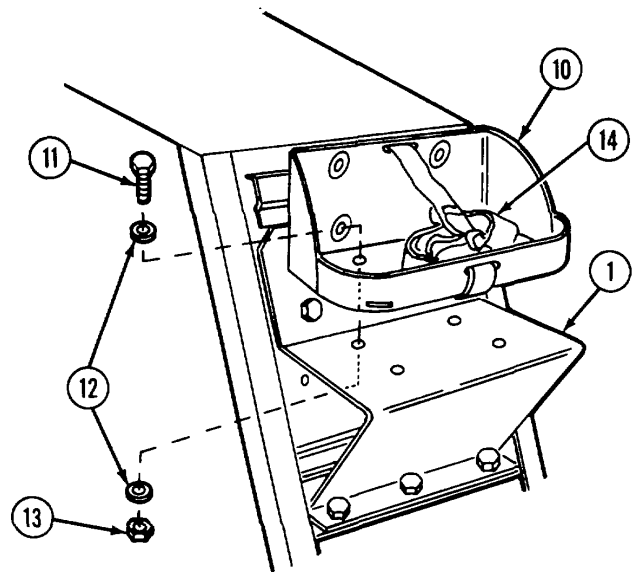

i. Fire Extinguisher.

INSTALLATION

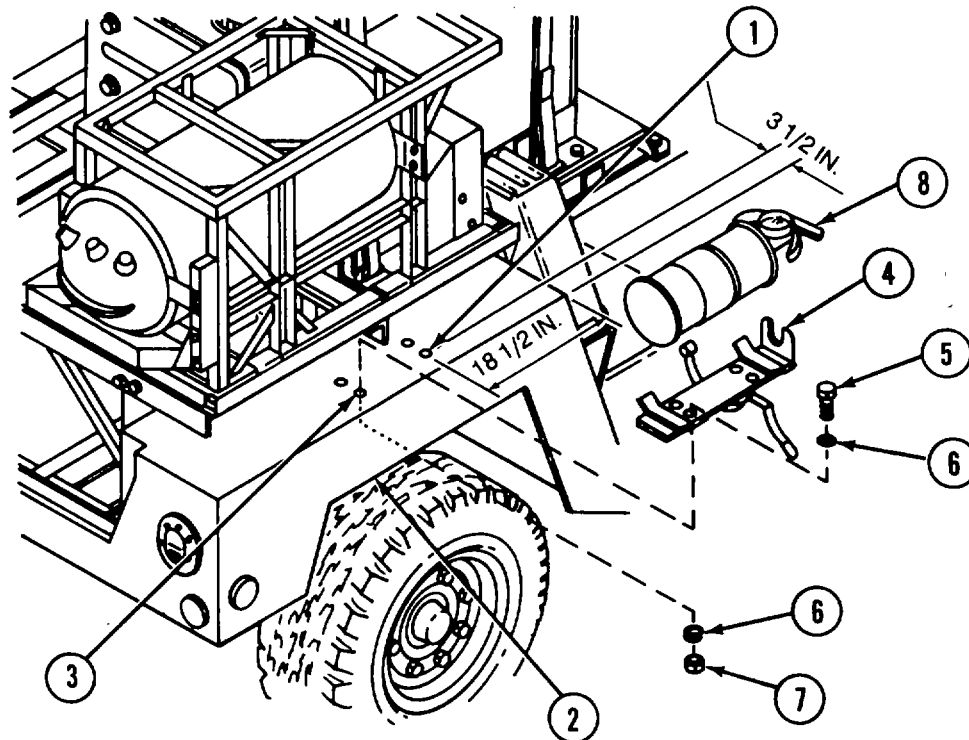

WARNING

Always wear eye protection when drilling. Eye injury may result if metal chips get into eyes.

Use a brush when cleaning up metal chips to avoid injury to hands.

NOTE

Left and right fire extinguisher brackets are installed the same way.

- a. Locate and mark hole (1) on top of wheelhouse (2) 18-1/2 inches from front edge and 3-1/2 inches from side.
- b. Locate and mark remaining three holes (3) using fire extinguisher bracket (4) as a template parallel to side of wheelhouse.
- c. Center punch and drill four 9/32-inch diameter holes.
- d. Install fire extinguisher bracket on wheelhouse with four screws (5), eight washers (6), and four nuts (7).
- e. Install fire extinguisher (8) in bracket.

2-5. INSTALLATION INSTRUCTIONS (CONT).

- j. Cable and Hose Assemblies.

INSTALLATION

1

- a. Release two latches (1) securing companion seat and battery box cover (2) to battery box (3).
- b. Remove companion seat and battery box cover from battery box (3) by lifting front of cover up and pulling it forward.

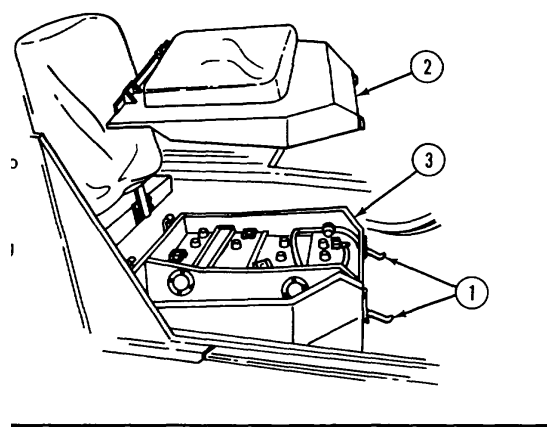

2

WARNING

Metal objects such as rings or tools can short circuit the battery and cause severe burns to personnel. Remove all jewelry before starting work. Do not allow tools to contact the vehicle when removing or installing battery cables.

- a. Disconnect vehicle ground cable (4) from terminal clamp (5) on battery.
- b. Disconnect vehicle positive cable (6) from terminal clamp (7) on battery.
- c. Remove interconnecting battery cable (8), battery holddown (9), and rear battery (10) from battery box (3). Refer to TM 9-2320-280-20.

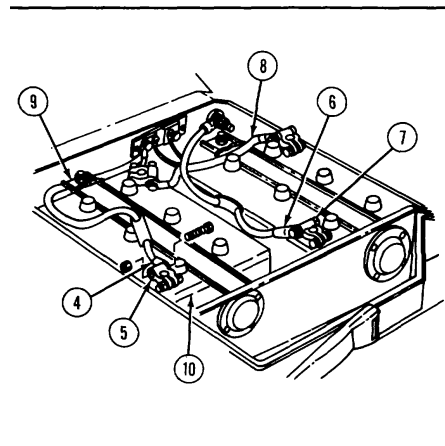

3

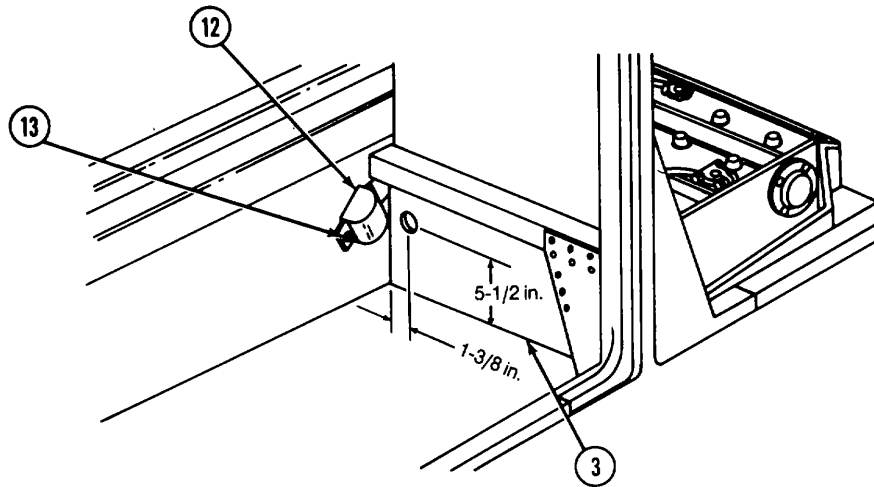

- a. Remove anchor bolt (11) securing seat belt assembly (12) to vehicle body and remove seat belt assembly.

WARNING

Always wear eye protection when drilling. Eye injury may result if metal chips get into eyes.

Use a brush when cleaning up metal chips to avoid injury to hands.

- b. Measure 1-3/8 inches from left outer edge of battery box (3) and scribe a vertical line. Measure up from bottom edge of battery box (3) 5-1/2 inches on scribed line and scribe a short horizontal line. Drill a pilot hole where the lines cross. Enlarge hole to 1-1/8 inches.

4

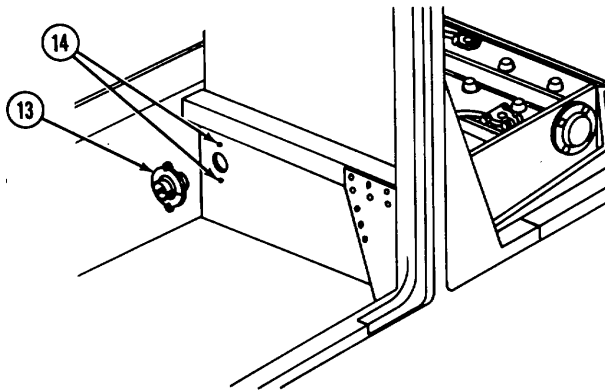

Using grommet (13) as a template, locate, mark, and drill two 3/16-inch holes (14) around 1-1/8-inch hole in battery box as shown.

2-5. INSTALLATION INSTRUCTIONS (CONT).

j. Cable and Hose Assemblies (Cont).

INSTALLATION (CONT)

5

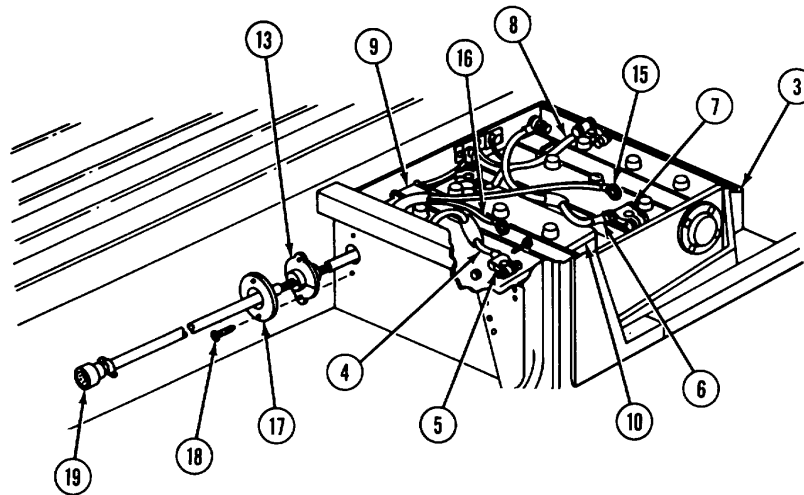

- a. Reinstall battery (10), battery holddown (9), and interconnecting battery cable (8) in battery box (3). Refer to TM 9-2320-280-20.
- b. Feed terminal ends of W1 cable assembly through 1-1/8-inch hole in battery box. Connect vehicle positive cable (6) and positive lead (15) of W1 to terminal clamp (7) of battery.
- c. Connect vehicle ground cable (4) and negative lead (16) of W1 cable assembly to negative terminal clamp (5) of battery.

NOTE

Grommet is split and retainer is a hinged type that spreads apart.

- d. Install grommet (13) of W1 cable assembly and secure grommet in battery box with retainer (17) and two self-tapping screws (18).
- e. Connect W1 cable assembly connector (19) to control panel connector 1J1.

6

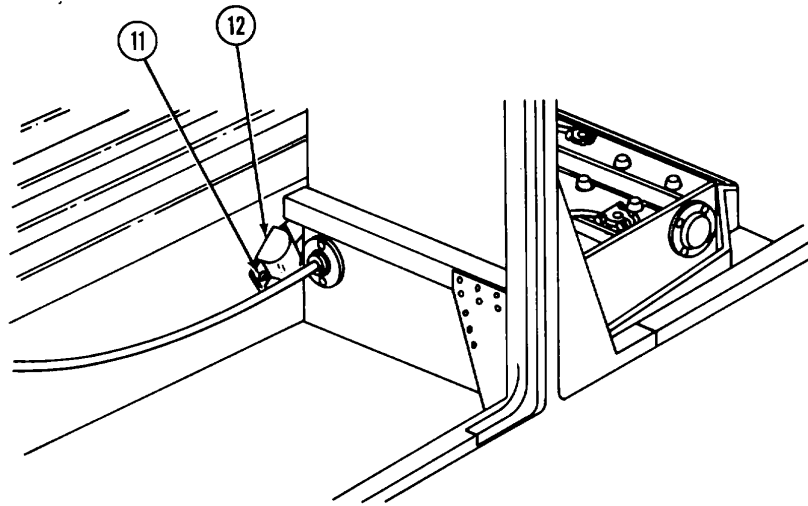

Reinstall seat belt assembly (12) to vehicle body with anchor bolt (11).

7

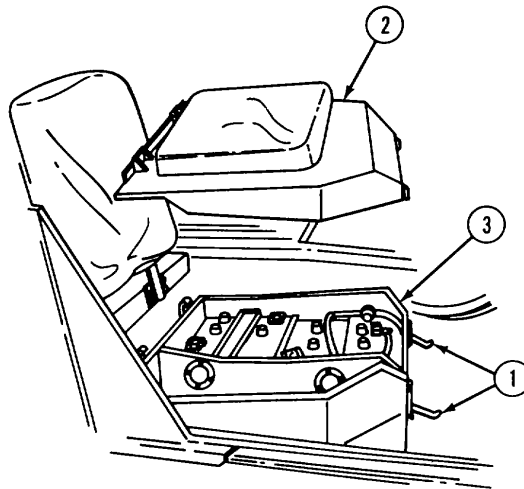

Position companion seat and battery box cover (2) on battery box (3) and secure with two latches (1).

2-5. INSTALLATION INSTRUCTIONS (CONT).

j. Cable and Hose Assemblies (Cont).

INSTALLATION (CONT)

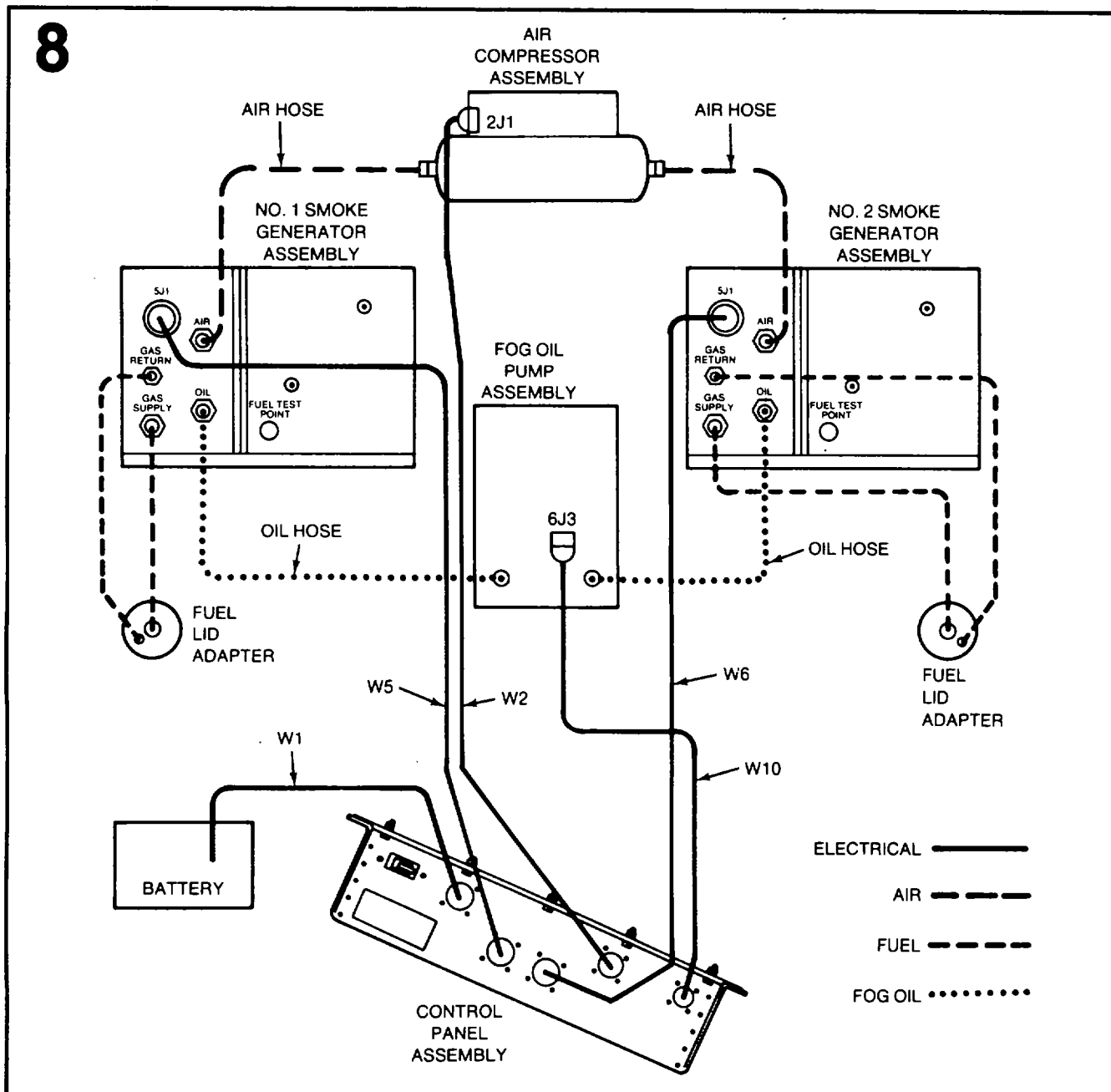

INTERCONNECTING DIAGRAM

Connect remaining cable and hose assemblies according to the interconnecting diagram. Route cables and hoses behind retaining straps of fog oil tank where possible.

2-6. OPERATIONAL CHECK.

- a. Perform before operation PMCS contained in TM 3-1040-279-12&P.
- b. Start and operate smoke generator set.

Section III. PREVENTIVE MAINTENANCE CHECKS AND SERVICES (PMCS)

2-7. PMCS PROCEDURES.

a. Purpose. The purpose of unit PMCS is to systematically and periodically inspect and service the M284 mounting kit.

- (1) To insure that the equipment is ready for operation at all times.
- (2) To perform those PMCS procedures that are beyond the capability of the operator/crew.
- (3) To discover and correct defects before they result in serious damage or failure requiring time consuming repairs or replacement.

b. Use.

(1) Use the semiannual schedule below as a check list each time you perform the PMCS to make sure that you perform all required procedures.

(2) Report and record all deficiencies and shortcomings, together with corrective actions taken, on DA Form 2404, Equipment Inspection and Maintenance Worksheet.

c. Explanation of Columns on the PMCS Schedule.

(1) Item number column. Checks and services are numbered in order of performance. Use this column as a source of item numbers for the TM Number Column on DA Form 2404, Equipment Inspection and Maintenance Worksheet, in recording results of PMCS.

(2) Item to be inspected column. The items listed in this column are divided into groups indicating the portion of the equipment of which they are part. The common name or official nomenclature as shown on the maintenance allocation chart (app B) is used for this purpose.

(3) Procedures column. This column briefly describes the procedure for performing the check or service. Whenever replacement or repair is recommended, a reference is made to a page number for the applicable maintenance instruction.

PREVENTIVE MAINTENANCE CHECKS AND SERVICES SEMIANNUAL SCHEDULE

Item No.	Item to be Inspected	Procedures
1	M284 Mounting Kit	<ul style="list-style-type: none"> a. Check all components to insure they are securely mounted to vehicle. Tighten loose bolts or replace missing hardware as required. b. Inspect components for rust, chipped paint or bare metal on painted surfaces. Repaint or touch up as necessary (p 2-20).
2	Fuel Lid Assemblies	Remove fuel lid assemblies from 5-gallon gasoline cans and inspect hoses for cracks and condition. Replace damaged hoses. Reinstall fuel lid assemblies.
3	Cable Assemblies	Check that cable assemblies are not cut, pinched, or otherwise damaged. Replace as required.
4	Hose Assemblies	Check for signs of leaks and that hoses are not cut, twisted, or collapsed. Replace or repair as required.

Section IV. M284 MAINTENANCE PROCEDURES

2-8. INTRODUCTION. This section contains maintenance procedures which are the responsibility of the unit maintenance technician as authorized by the maintenance allocation chart (MAC) (app B) and source, maintenance, and recoverability (SMR) coded items in the repair parts and special tools list (RPSTL).

2-9. M284 MOUNTING KIT.

This task covers painting and replacement of:

- | | |
|---------------------------------|-----------------------------------|
| a. Generator Bracket Assemblies | g. Control Panel Mounting Bracket |
| b. Frame Assembly | h. Fuel Lid Assembly |
| c. Compressor Mounting Plate | i. Cable Assembly W1 (Power) |
| d. Fuel Can Bracket Assembly | j. Air Hose Assemblies |
| e. Fuel Can Base Plate | k. Oil Hose Assemblies |
| f. Fire Extinguisher | |

PAINTING

INITIAL SETUP

Materials/Parts

- Abrasive cloth (item 3, app D)
- Dry cleaning solvent (item 4, app D)
- Polyurethane coating (item 7, app D)
- Primer coating (item 5, app D)
- Rag (item 8, app D)
- Paint brush (item 2, app D)

References

TM 43-0139

- a. Remove corrosion and chipped paint.

WARNING

Dry cleaning solvent is flammable and toxic. Keep it away from heat or open flames. Use in well ventilated area. Avoid breathing vapors. Failure to observe precautions may result in injury to personnel or damage to equipment.

- b. Clean surface to be painted using rags and dry cleaning solvent.
- c. Paint surface with primer coating and polyurethane coating. See TM 43-0139.

a. Generator Bracket Assemblies.

INITIAL SETUP

Tools Personnel
 General Mechanic's Tool Kit
 SC 5180-90-N26

Required
 One mechanic
 One assistant

REMOVAL/INSTALLATION

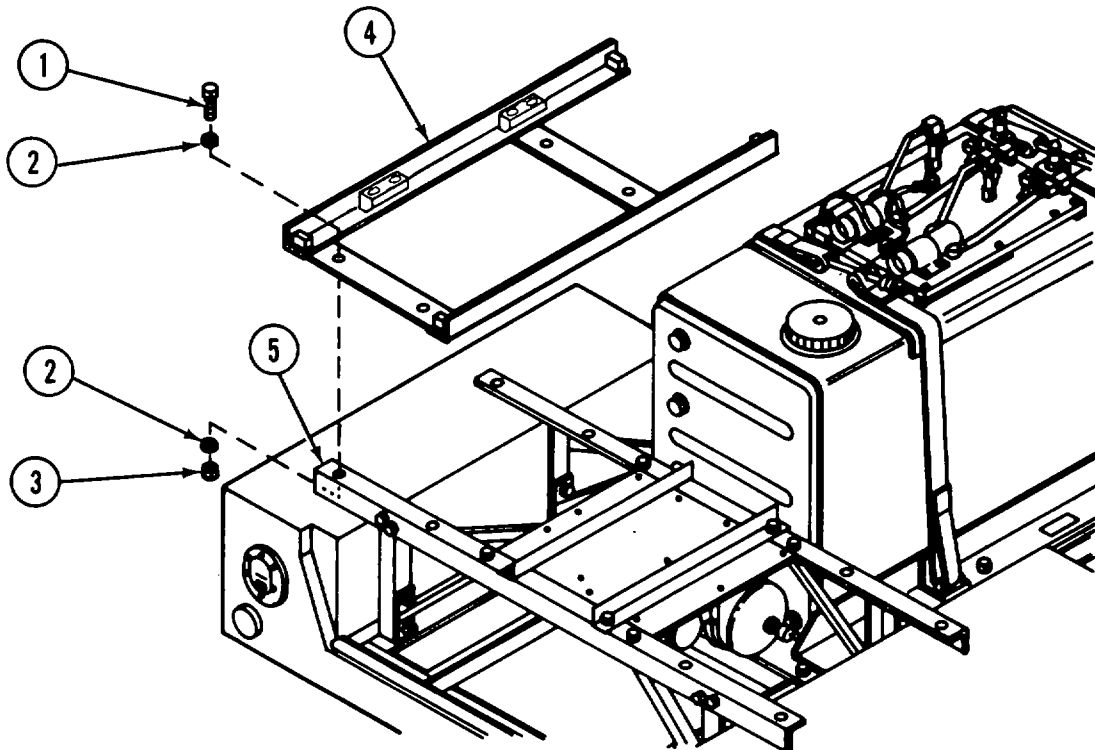

NOTE

Removal and installation are the same for right and left bracket assemblies. Left bracket shown.

- a. Remove M54 smoke generator (p 2-45).
- b. Remove four screws (1), eight washers (2), and four nuts (3) securing generator bracket (4) to frame assembly (5). Remove generator bracket.
- c. Install generator bracket (4) on frame assembly (5) with four screws (1), eight washers (2), and four nuts (3).
- d. Install M54 smoke generator (p 2-47).

2-9. M284 MOUNTING KIT (CONT).

b. Frame Assembly.

INITIAL SETUP

Tools

- Shop area with overhead chain hoise or 5-ton wrecker
- Drain hose (fig E-1, app E)

Tools

- General Mechanic's Tool Kit SC 5180-90-N26
- Automotive Shop Equipment
- SC 4910-95-CL-A74:
- Torque wrench 0-170 ft lbs
- Drain pan

Personnel Required

- One mechanic
- One assistant

REMOVAL

1

- a. Remove generator brackets (p 2-21).
- b. Remove air compressor assembly (p 2-53)
- c. Disconnect hose assemblies (1) from quick disconnect fittings (2) on fog oil pump assembly (3).
- d. Disconnect cable assembly (4) from cornector 6J3 (5) on fog oil pump assembly (3).

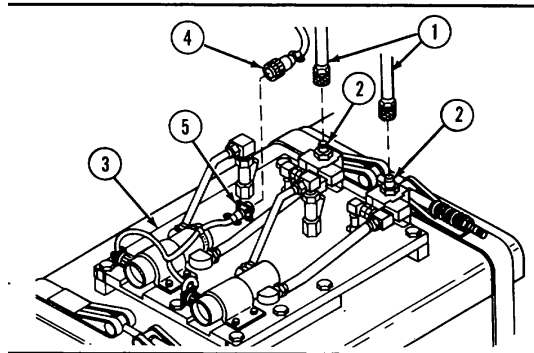

2

- a. Connect drain hose to plug valve (6) on fog oil tank (7) and drain tank into a suitable container. Close plug valve (6)
- b. Remove 6 screws (8), 12 washers (9), and 6 nuts (10) securing fog oil tank assembly (7) to frame assembly (11).
- c. Remove fog oil tank assembly with pump assembly from frame assembly.

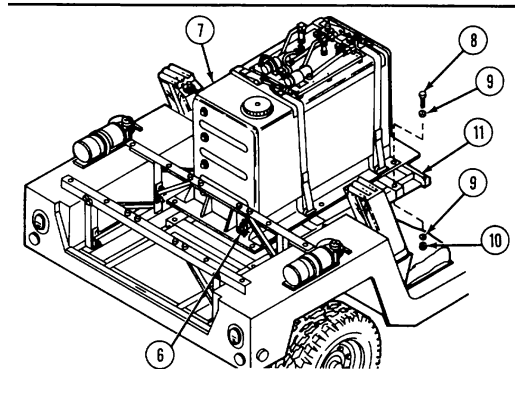

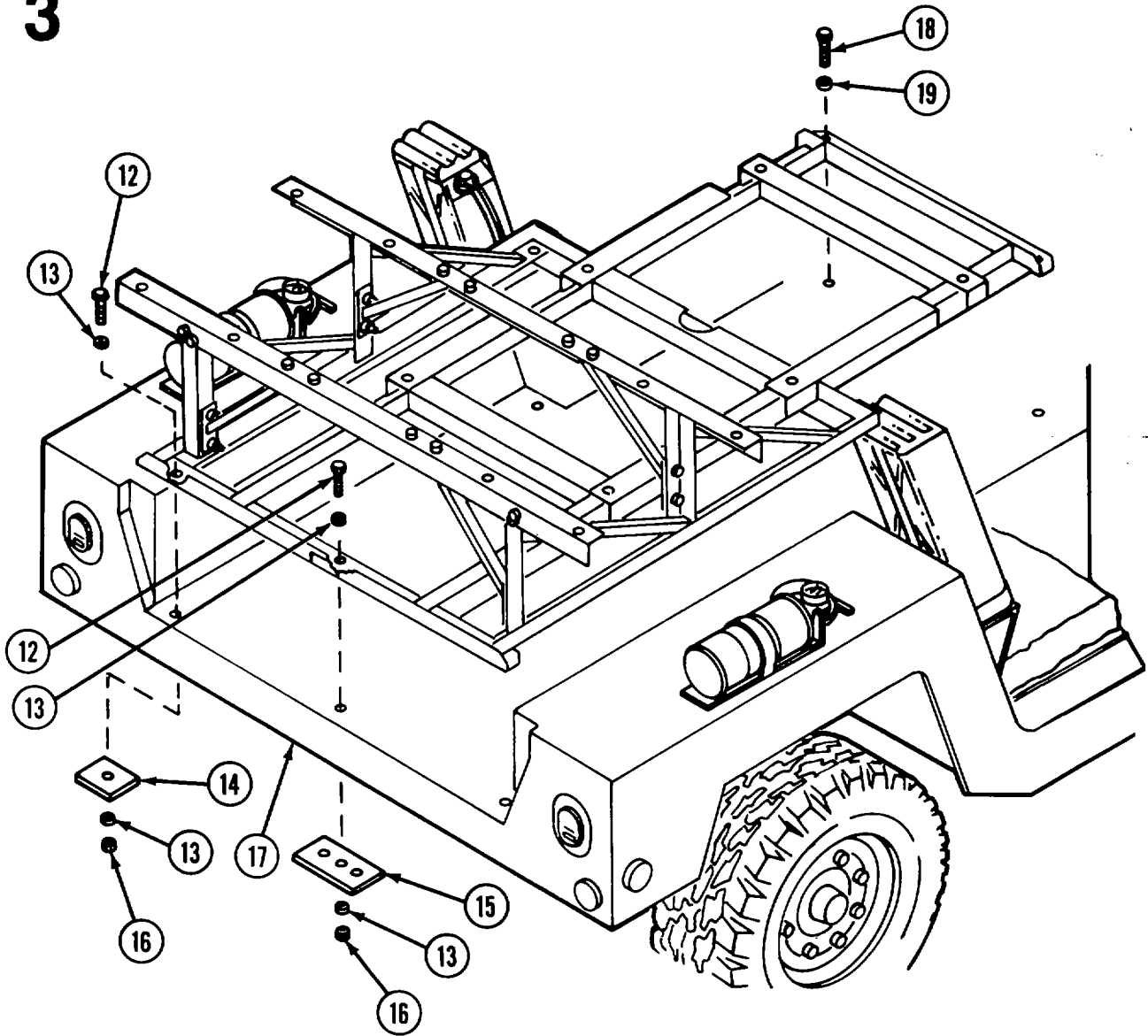
3

- a. Remove three screws (12), six washers (13), two spacer plates (14), one spacer plate (15), and three nuts (16) securing rear of frame assembly to cargo bed (17).
- b. Remove four screws (18) and washers (19) securing front of frame assembly to cargo bed (17). Remove frame assembly.

2-9. M284 MOUNTING KIT (CONT).

- b. Frame Assembly (Cont).
 - a. Install frame assembly (p 2-2).
 - b. Install fog oil tank assembly on frame assembly (p 2-4, steps 1 and 2).
 - c. Connect cable assembly (4) to connector 6J3 (5) on fog oil pump assembly (3).
 - d. Connect hose assemblies (1) to quick-disconnect fittings (2) on fog oil pump assembly (3).
 - e. Install air compressor assembly (p 2-54).
 - f. Install generator brackets and smoke generators (p 2-21).

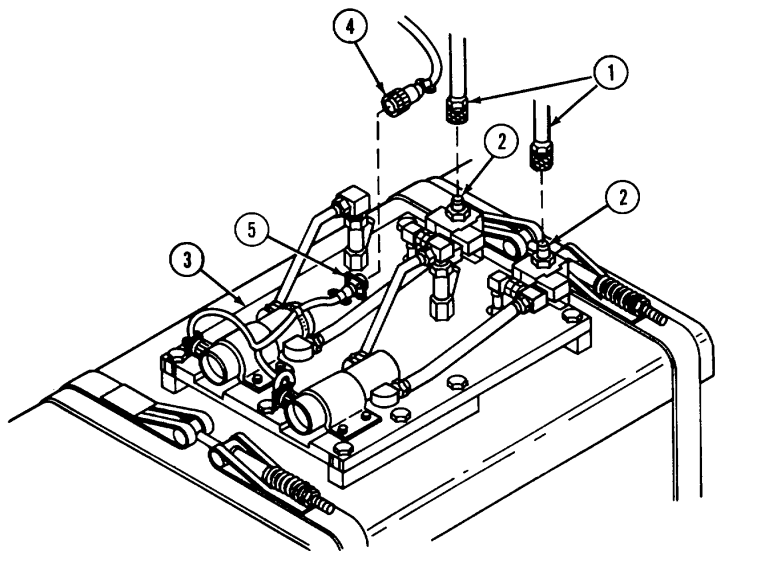

INSTALLATION

- c. Compressor Mounting Plate.

REMOVAL/INSTALLATION

Refer to removal and installation procedures for air compressor assembly (p 2-52 and 54).

- d. Fuel Can Bracket Assembly.

INITIAL SETUP

Tools

General Mechanic's Tool Kit
SC 5180-90-N26

REMOVAL/INSTALLATION

NOTE

Procedure is the same for right and left fuel can bracket assemblies.

- a. Remove four screws (1), eight washers (2) and four nuts (3) securing fuel can bracket assembly (4) to fuel can base plate (5).
- b. Install fuel can bracket assembly (4) on fuel can base plate (5) with four screws (1), eight washers (2), and four nuts (3).
- e. Fuel Can Base Plate.

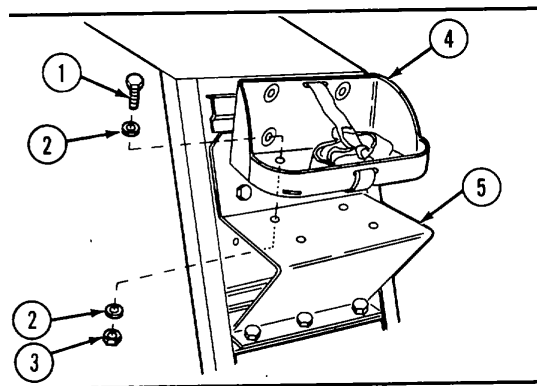

INITIAL SETUP

Tools

General Mechanic's Tool Kit SC 5180-90-N26

REMOVAL/INSTALLATION

NOTE

Procedure is the same for right and left fuel can base plates. Right side shown.

- a. Remove fuel can bracket assembly (p 2-25).
- b. Remove 7 screws (1), 14 washers (2), and 7 nuts (3) securing fuel can base plate (4) and base plate doublers (5) to wheelhouse (6).
- c. Install fuel can base plate (4) on wheelhouse (6) with base plate doublers (5), 7 screws (1), 14 washers (2), and 7 nuts (3).
- d. Install fuel can bracket assembly (p 2-25)

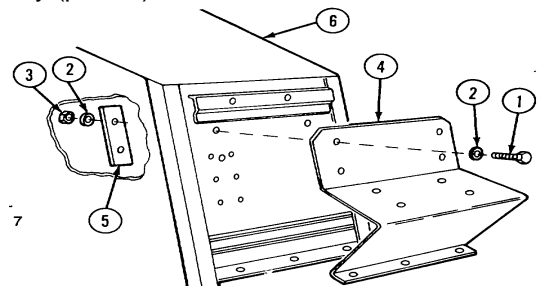

2-9. M284 MOUNTING KIT (CONT).

f. Fire Extinguisher.

INITIAL SETUP

Tools

General Mechanic's Tool Kit
SC 5180-90-N26

REMOVAL/INSTALLATION

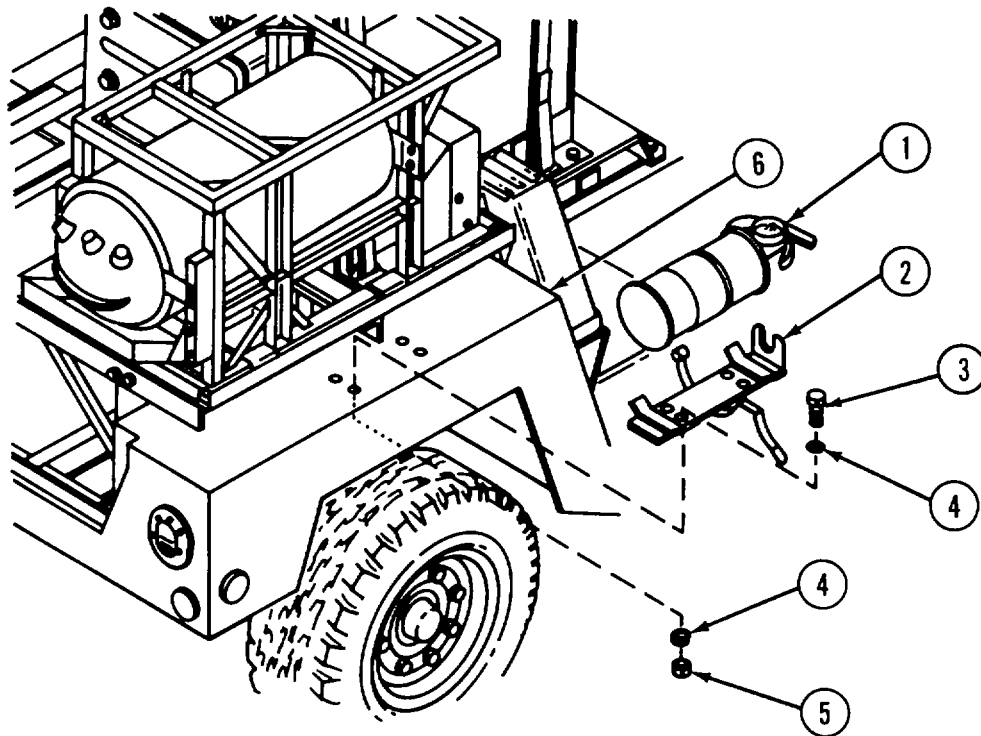

NOTE

Procedure is the same for right and left fire extinguishers.

- a. Remove fire extinguisher (1) from bracket (2).
- b. Remove four screws (3), eight washers (4), and four nuts (5) securing bracket on wheelhouse (6).
- c. Install bracket (2) on wheelhouse (6) with four screws (3), eight washers (4), and four nuts (5).
- d. Install fire extinguisher (1) in bracket.

- g. Control Panel Mounting Bracket.

INITIAL SETUP

Tools

General Mechanic's Tool Kit
SC 5180-90-N26

REMOVAL/INSTALLATION

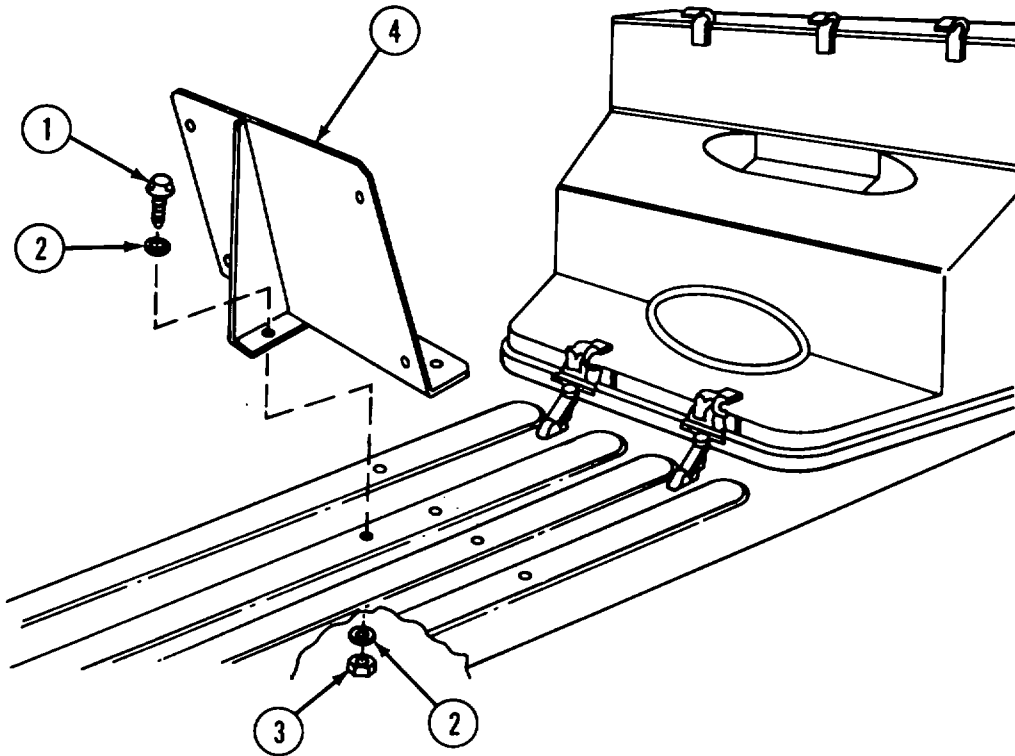

- Remove control panel assembly (p 2-48).
- Remove 5 screws (1), 10 washers (2), and 5 nuts (3) securing control panel mounting bracket (4) to ribbed floor panel of vehicle.
- Install control panel mounting bracket (4) on ribbed floor panel of vehicle with 5 screws (1), 10 washers (2) and 5 nuts (3).
- Install control panel assembly (p 2-49).

2-9. M284 MOUNTING KIT (CONT).

h. Fuel Lid Assembly.

INITIAL SETUP

Tools

General Mechanic's Tool Kit
SC 5180-90-N26

REMOVAL/INSTALLATION

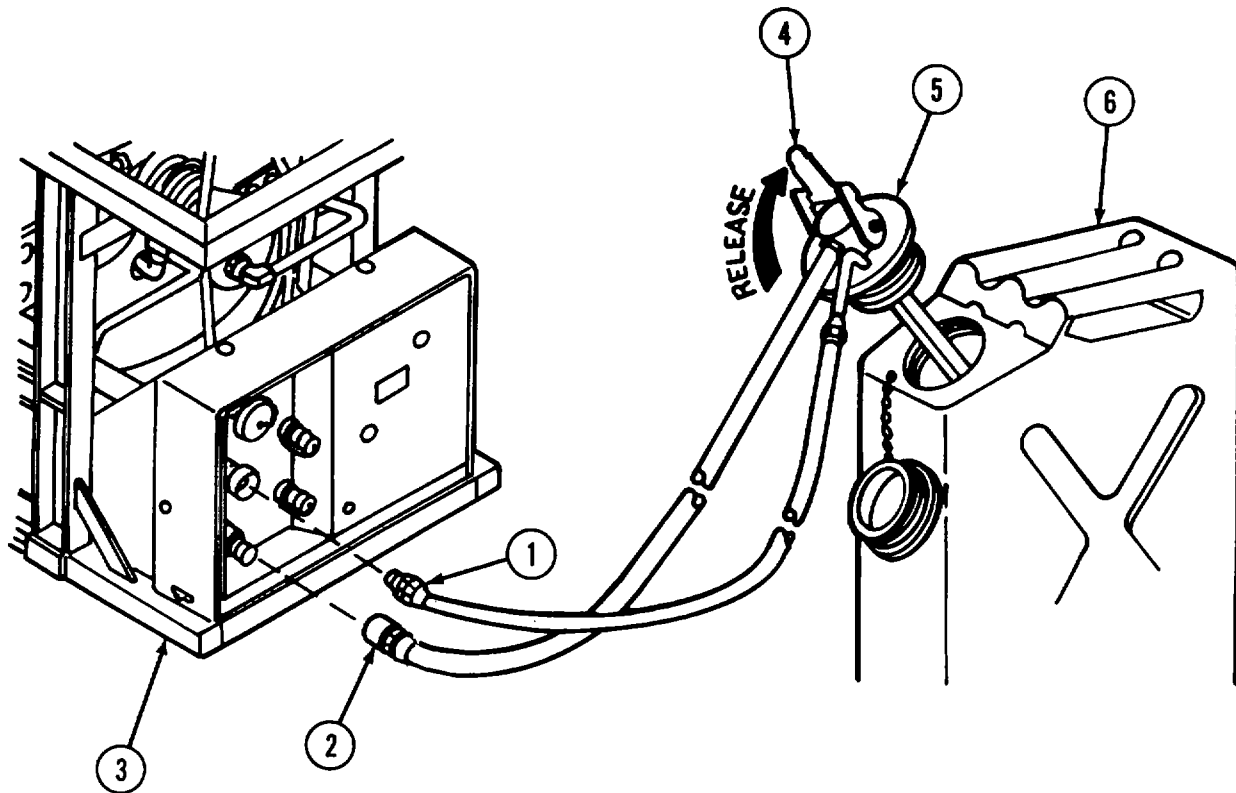

WARNING

Gasoline is very flammable. Do not allow open flames, sparks, or smoking in the area while performing maintenance.

- Disconnect gas supply hose (1) and gas return hose (2) from quick-disconnect fittings at smoke generator (3). Install protective caps.
- Set lever (4) on fuel lid assembly (5) to release position and lift fuel lid assembly from gas can (6). Install cap on gas can.
- Remove cap from gas can. Insert fuel lid assembly (5) in gas can (6). Pull lever (4) up until fuel lid assembly (5) is secure in gas can.
- Remove protective caps. Connect gas supply hose (1) and gas return hose (2) to quick-disconnect fittings at smoke generator (3).

- i. Cable Assembly W1.

INITIAL SETUP

Tools

General Mechanic's Tool Kit
SC 5180-90-N26

REMOVAL

1

- a. Release two latches (1) securing companion seat and battery box cover (2) to battery box.
- b. Remove companion seat and battery box cover from battery box (3) by lifting front of cover up and pulling it forward.

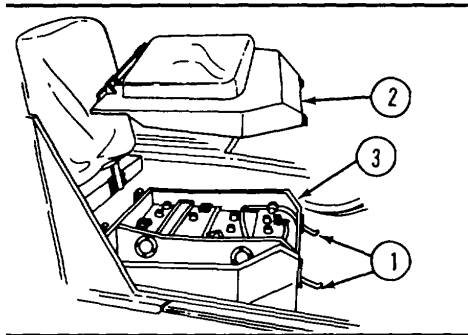

2

WARNING

Metal objects such as rings or tools can short circuit the battery and cause severe burns to personnel. Remove all jewelry before starting work. Do not allow tools to contact the vehicle when removing or installing battery cables.

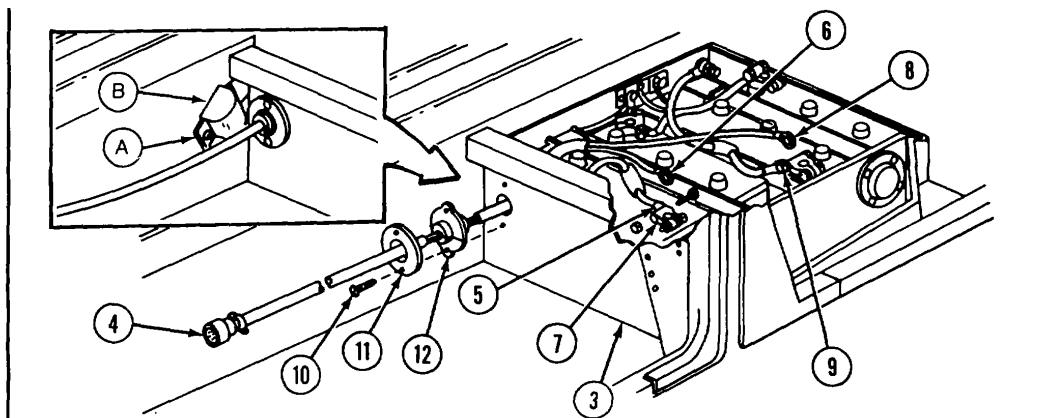

- a. Remove anchor bolt (A) securing seat belt assembly (B) to vehicle body and remove seat belt assembly.
- b. Disconnect cable assembly W1 (4) from connector 1 J 1 on control panel.
- c. Disconnect vehicle ground cable (5) and negative lead (6) of cable assembly W1 from terminal clamp (7) of battery.
- d. Disconnect positive lead (8) of cable assembly from terminal clamp (9) of battery.
- e. Remove two screws (10) securing retainer (11) and grommet (12) to battery box (3).
- f. Pull cable assembly from hole in battery box. Remove retainer and grommet from cable assembly.

2-9. M284 MOUNTING KIT (CONT).

i. Cable Assembly W1 (Cont).

INSTALLATION

1

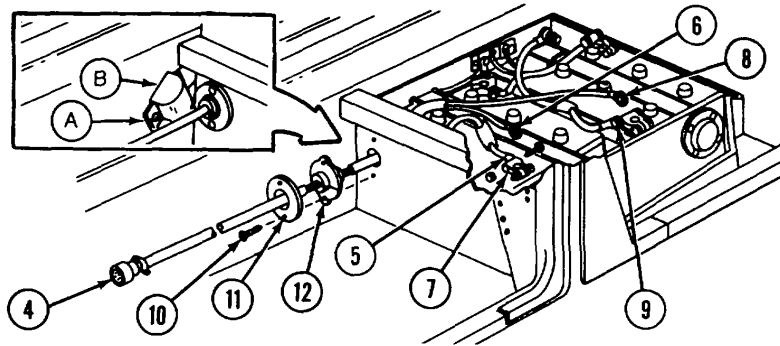

- a. Feed terminal ends of cable assembly through hole in battery box and connect positive lead (8) to positive terminal clamp (9) of battery.
- b. Connect vehicle ground cable (5) and negative lead (6) of cable assembly W1 to negative terminal clamp (7) of battery.
- c. Install grommet (12) on cable assembly W1 and secure grommet in battery box with retainer (11) and two screws (10).
- d. Reinstall seat belt assembly (B) to vehicle body with anchor bolt (A).
- e. Connect cable assembly W1 (4) to connector 1J1 on control panel.

2

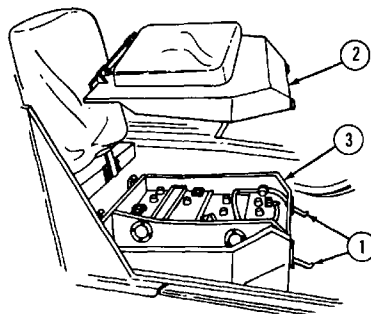

Position companion seat and battery box cover (2) on battery box (3) and secure with two latches (1).

j. Air Hose Assemblies.

REMOVAL/INSTALLATION

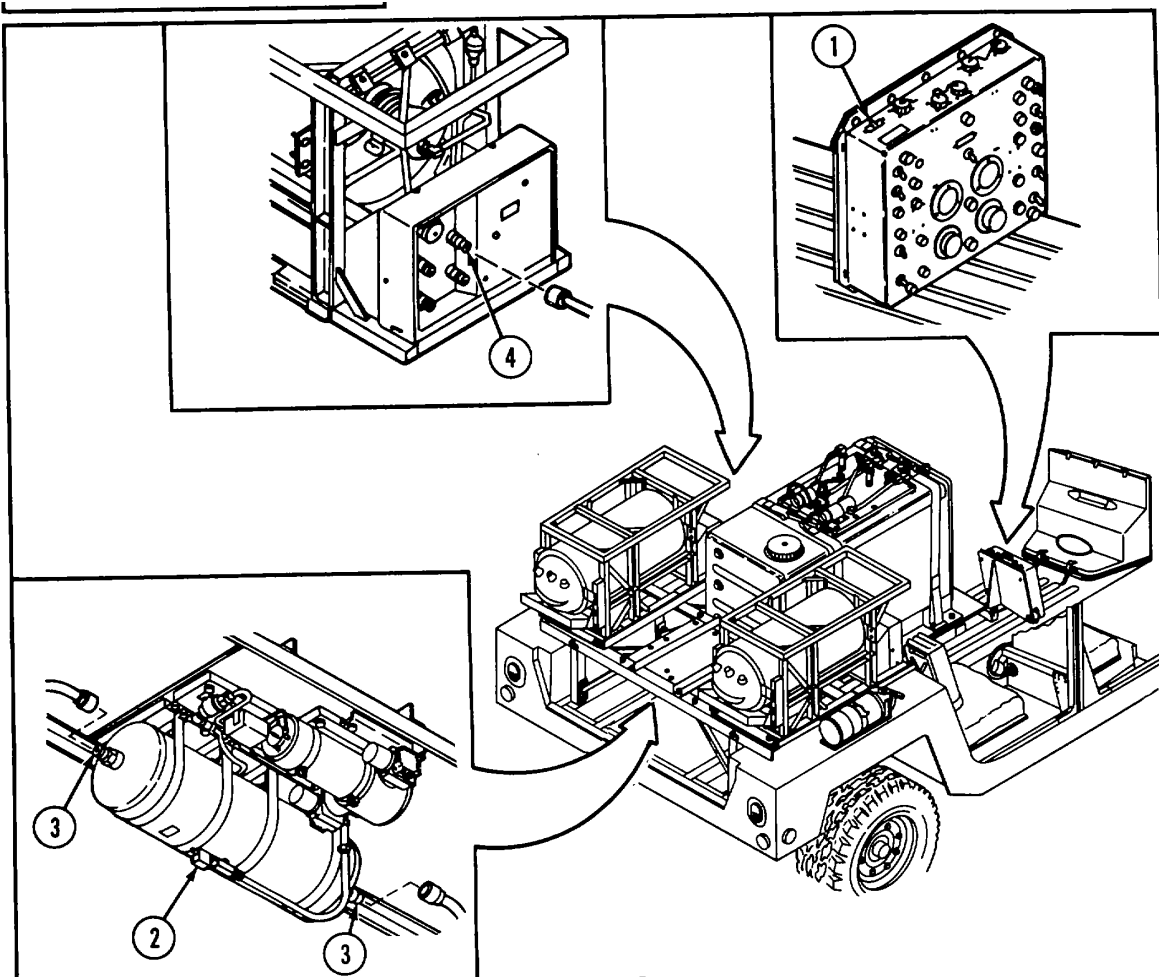

WARNING

Air compressor tank is pressurized to 63 psig. Bleed air from tank before attempting maintenance or disconnecting hoses. The bleed air may contain dirt particles. Keep face away from escaping air to avoid possible eye injury.

- a. Set circuit breaker CB1 (1) on control panel to OFF.
- b. Bleed air from air compressor tank by pressing control valve (2).
- c. Disconnect air hose assembly from coupling (3) on air compressor assembly and coupling (4) on smoke generator.
- d. Connect air hose assembly to coupling (3) on air compressor assembly and coupling (4) on smoke generator.

2-9. M284 MOUNTING KIT (CONT)

k. Oil Hose Assemblies.

REMOVAL/INSTALLATION

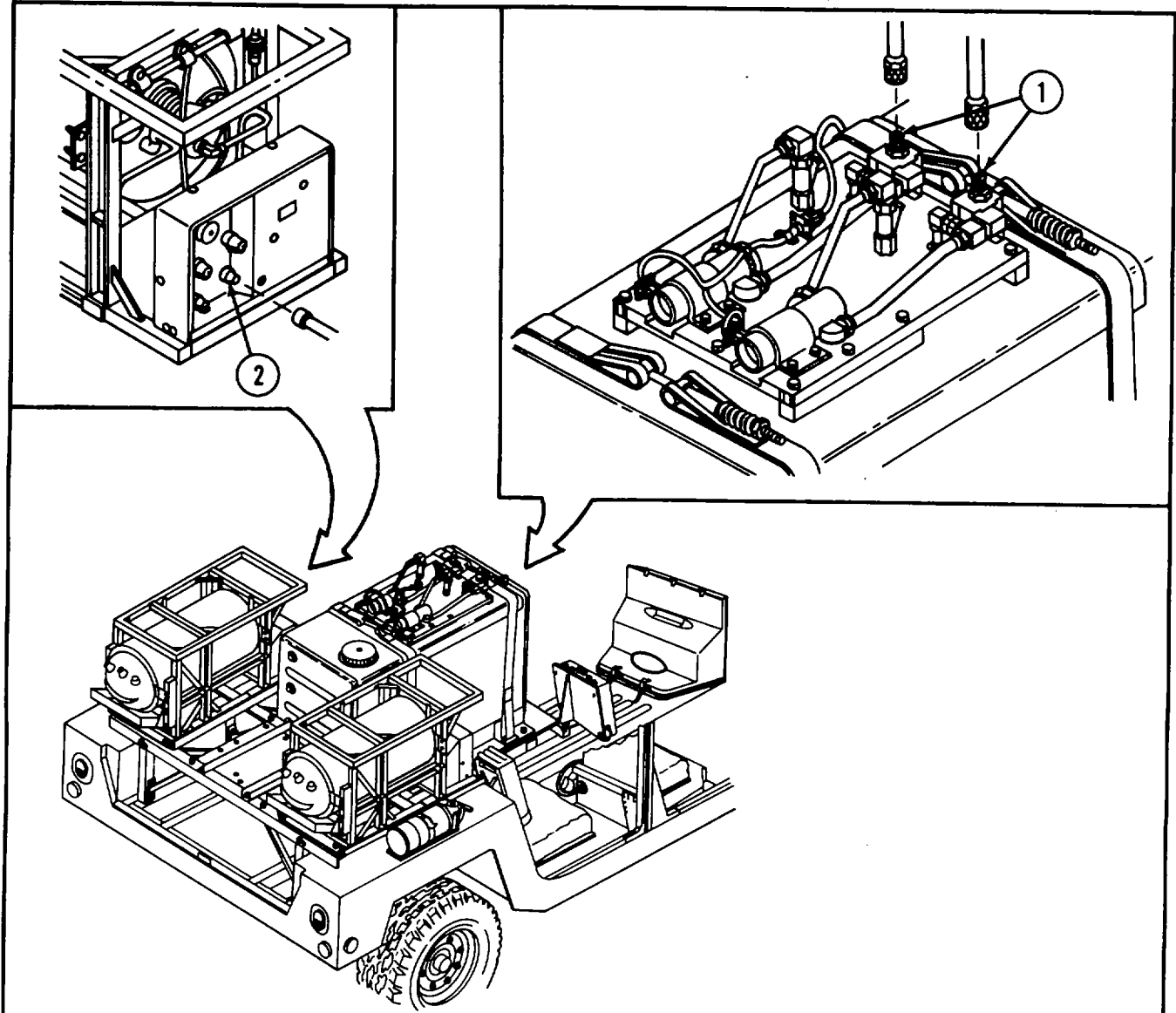

WARNING

Surfaces covered with fog oil will become slippery and may cause personnel injury due to falls. Clean up all spillage or leakage of fog oil. Avoid spilling fog oil. Do not drain fog oil near open flames or while smoking.

- a. Disconnect oil hose assembly from coupling (1) on fog oil pump assembly and coupling (2) on smoke generator.
- b. Connect oil hose assembly to coupling (2) on smoke generator and coupling (1) on fog oil pump assembly.

2-10. GENERATOR BRACKETS.

This task covers replacement of connecting links.

INITIAL SETUP

Tools

General Mechanic's Tool Kit
SC 5180-90-N26

REMOVAL/INSTALLATION

- a. Remove screw (1), two washers (2), lockwasher (3) and nut (4) securing connecting link (5) to generator bracket (6).
- b. Install connecting link (5) on generator bracket (6) with screw (1), two washers (2), lockwasher (3) and nut (4).

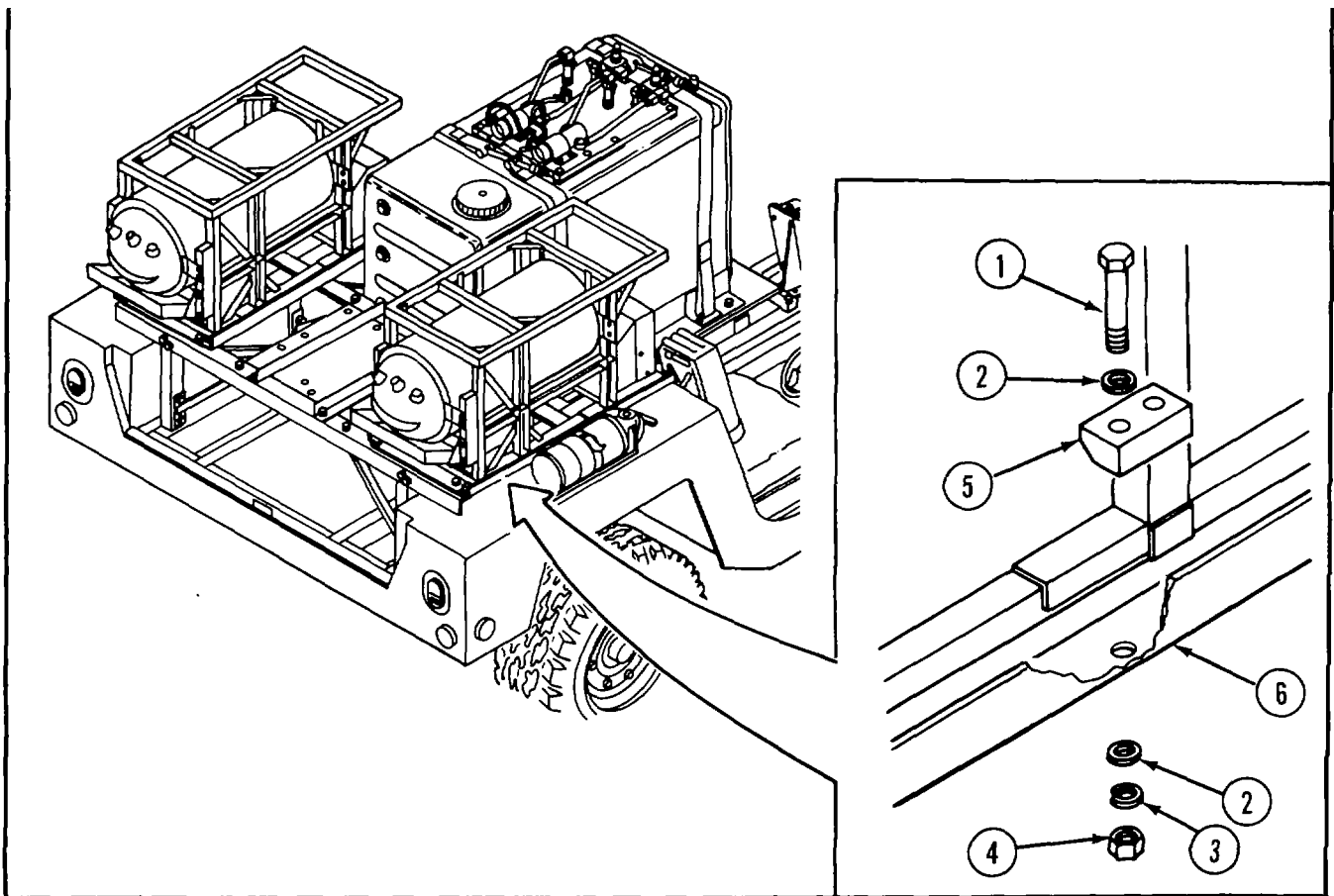

2-11. FRAME ASSEMBLY.

This task covers replacement of:

- a. Front Support Legs
- b. Rear Support Legs
- c. Generator Support Angles (p 2-36)
- d. ID Plate

- a. Front Support Legs.

INITIAL SETUP

Tools
 General Mechanic's Tool Kit
 SC 5180-90-N26

Personnel Required
 One mechanic
 One assistant

REMOVAL/INSTALLATION

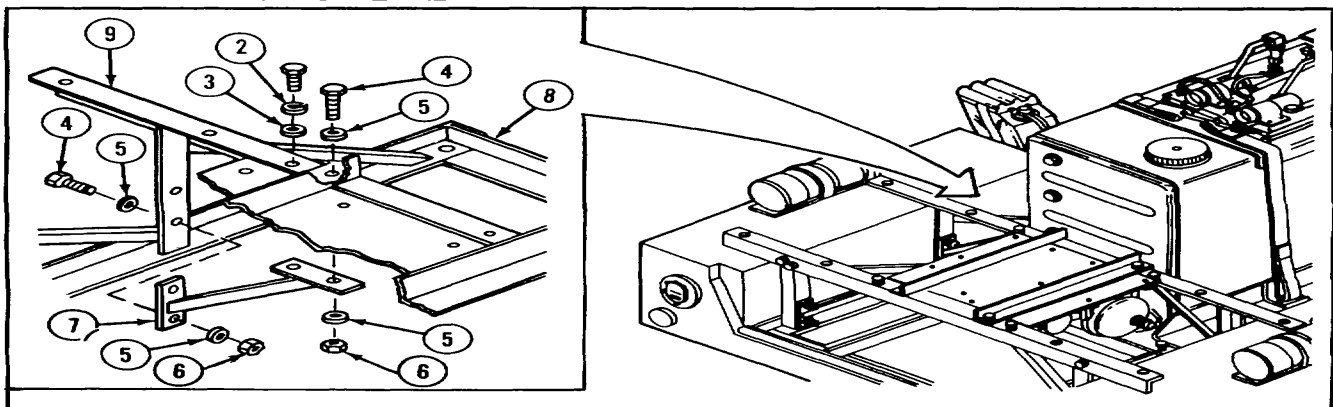

NOTE

Procedure is the same for right and left support legs.

- a. Remove smoke generator (p2-50) and generator bracket assembly (p2-21).
- b. Remove screw (1), lockwasher (2), washer (3), and three screws (4), six washers (5), and three nuts (6) securing front support leg (7) to frame (8) and generator support angle (9).
- c. Install front support leg (7) between frame (8) and generator support angle (9) with screw (1), lockwasher (2), washer (3), and three screws (4), six washers (5), and three nuts (6).
- d. Install generator bracket assembly(p2-21) and smoke generator (p2-51).

b. Rear Support Legs.

INITIAL SETUP

Tools
 General Mechanic's Tool Kit
 SC 5180-90-N26

Personnel Required
 One mechanic
 One assistant

REMOVAL/INSTALLATION

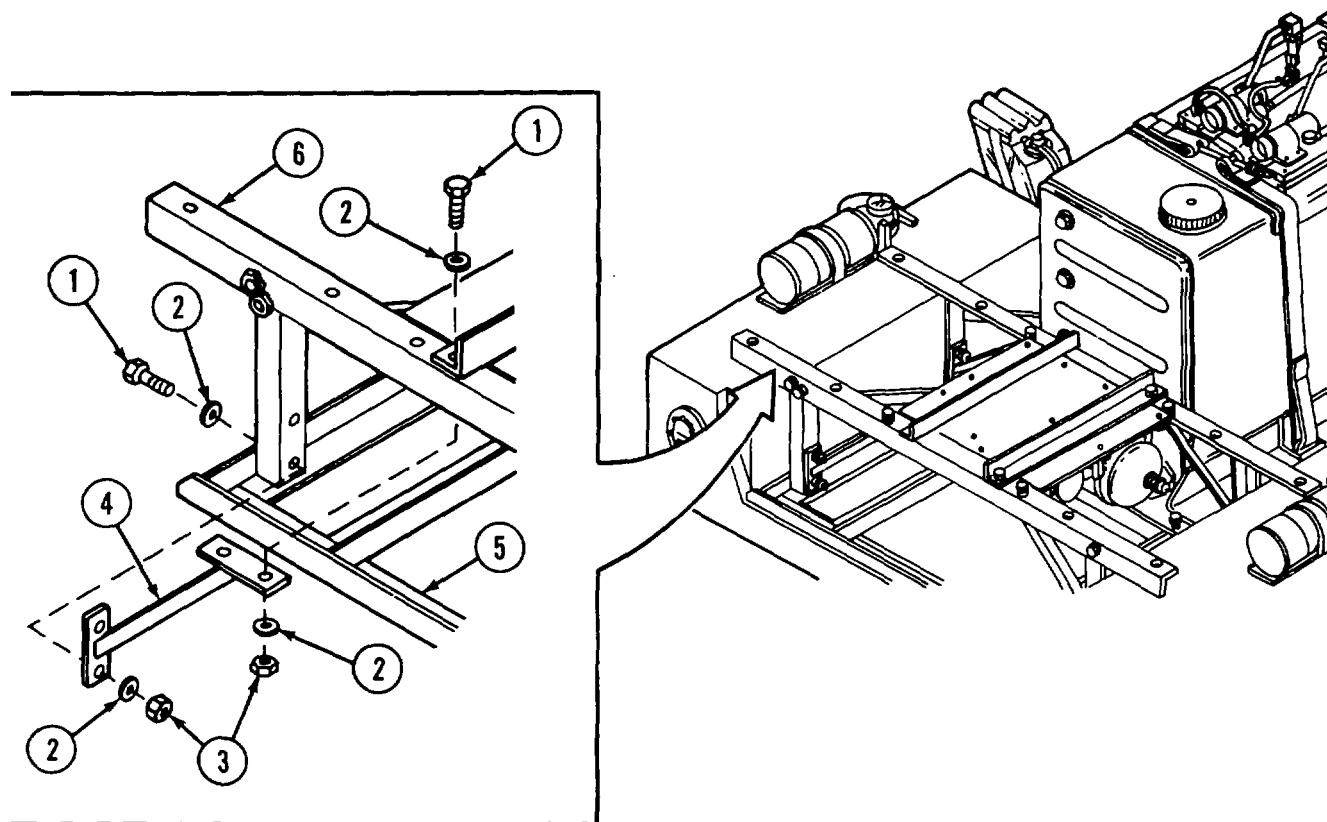
**Note**

Procedure is the same for right and left support legs.

- Remove smoke generator (p2-45) and generator bracket assembly(p2-21)
- Remove four screws (1), eight washers (2), and four nuts(3) securing rear support leg (4) to frame (5) and generator support angle(6).
- Install rear support leg (4) between frame (5) and generator support angle (6) with four screws (1), eight washers(2), and four nuts (3).
- Install generator bracket assembly (p 2-21) and smoke generator (p 2-47).

2-11. FRAME ASSEMBLY(CONT).*c. Generator Support Angels.***INITIAL SETUP**

Tools
 General Mechanic's Tool Kit
 SC 5180-90-N26

Personnel Required
 One mechanic
 One assistant

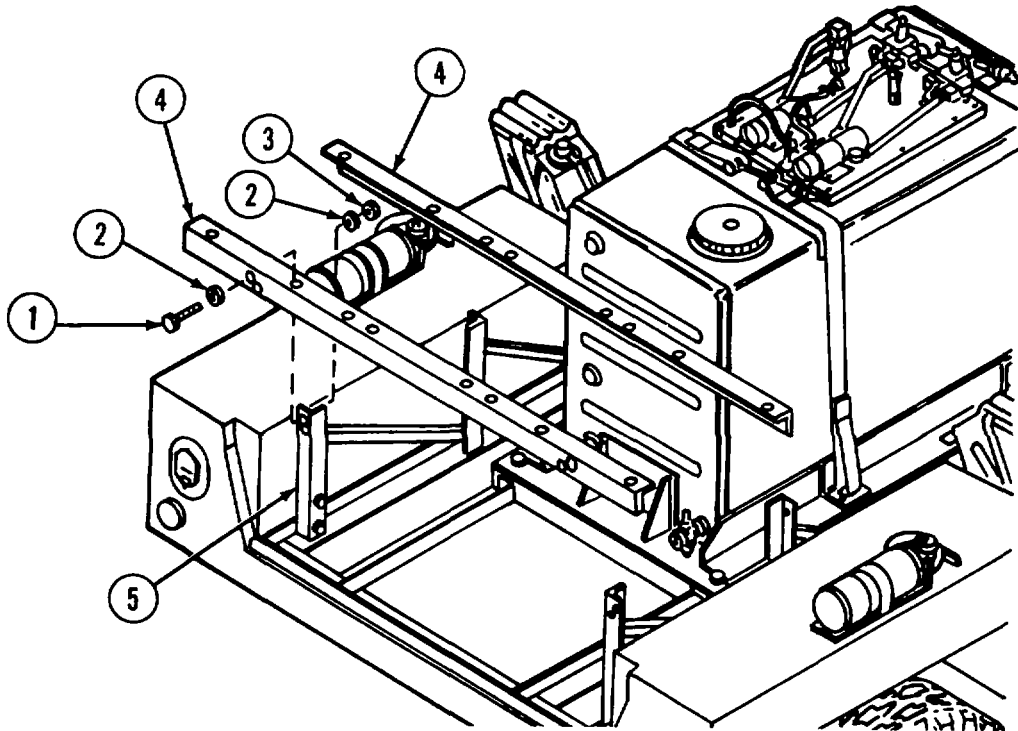
REMOVAL/INSTALLATION

- a. Remove smoke generators (p 2-45) and generator bracket assemblies (p 2-21).
- b. Remove front and rear support legs from support angles only (p 2-34 and 35).
- c. Remove air compressor (p 2-52, step 1).
- d. Remove 8 screws (1), 16 washers (2), and 8 nuts (3) securing generator support angles (4) to frame assembly (5).
- e. Install generator support angles (4) on frame assembly (5) with 8 screws (1), 16 washers (2), and 8 nuts (3).
- f. Install air compressor (p 2-54, steps 1 and 2).
- g. Install front and rear support legs (p 2-34 and 35). Install generator bracket assemblies (p 2-21) and smoke generators (p 2-47).

d. ID Plate.

INITIAL SETUP

Tools

General Mechanic's Tool Kit
SC 5180-90-N26

Materials/Parts

Abrasive cloth (item 3, app D)
Dry cleaning solvent (item 4, app D)
Polyurethane coating (item 7, app D)
Primer coating (item 5, app D)
Rag (item 8, app D)
Paint brush (item 2, app D)

REMOVAL/INSTALLATION

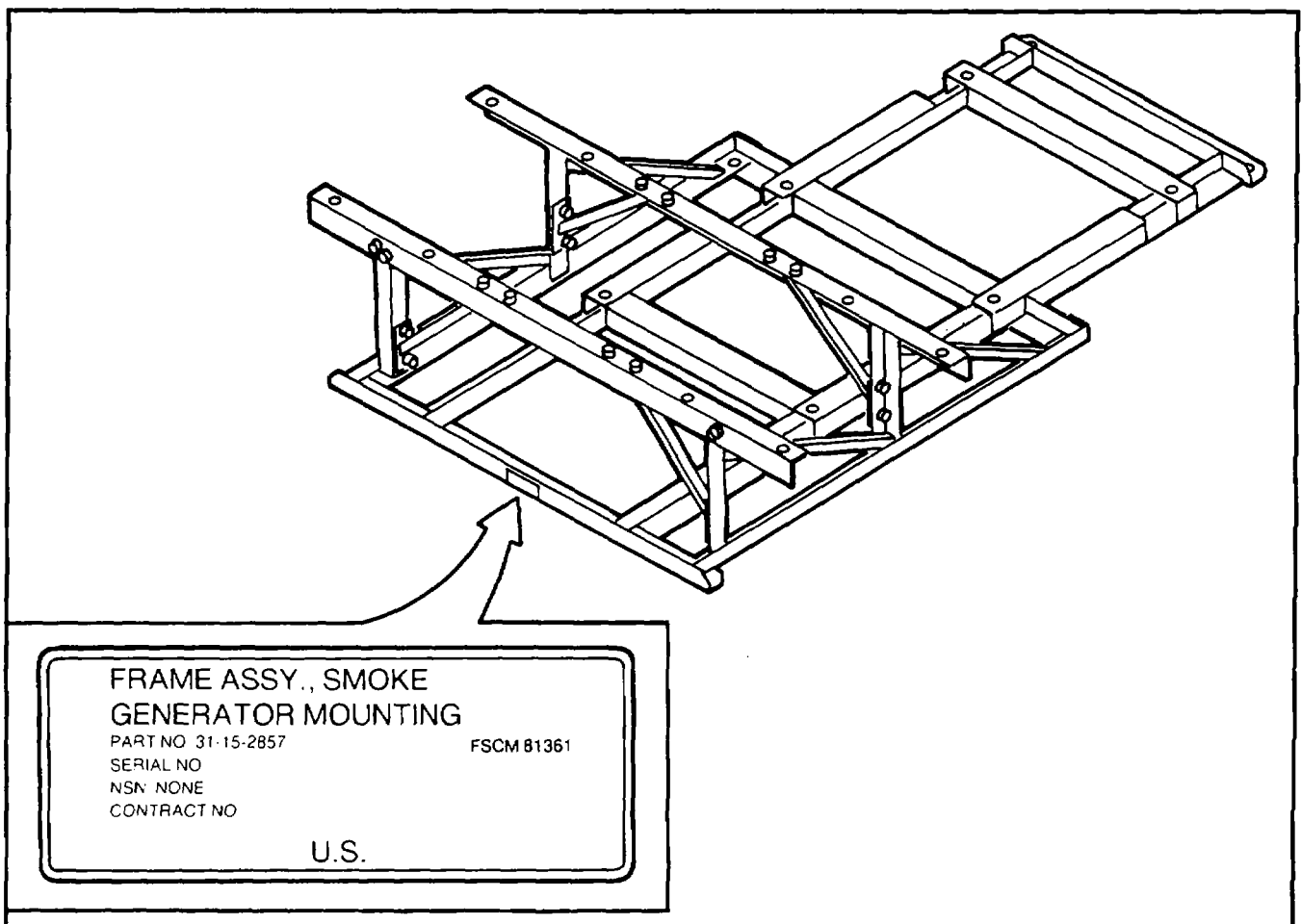

- a. Lift edge of plate with a sharp tool and pull plate completely off mounting surface.

WARNING

Dry cleaning solvent is flammable and toxic. Keep it away from heat or open flames. Use in well ventilated area. Avoid breathing vapors.

- b. Thoroughly clean mounting surface with dry cleaning solvent. Mounting surface must be free of all contamination such as oil, grease, dirt, or any foreign matter. Touchup paint as necessary (p 2-20).
- c. Peel back paper from adhesive backing on plate. Mount plate and apply pressure to plate surface.

2-12. AIR HOSE ASSEMBLY.

This task covers: Repair

INITIAL SETUP

Facilities and Equipment

Air hose (fig. E-2, app E)

Equipment Condition

Air hose removed from equipment (p 2-31).

Tools

General Mechanic's Tool Kit
SC 5180-90-N26

REPAIR

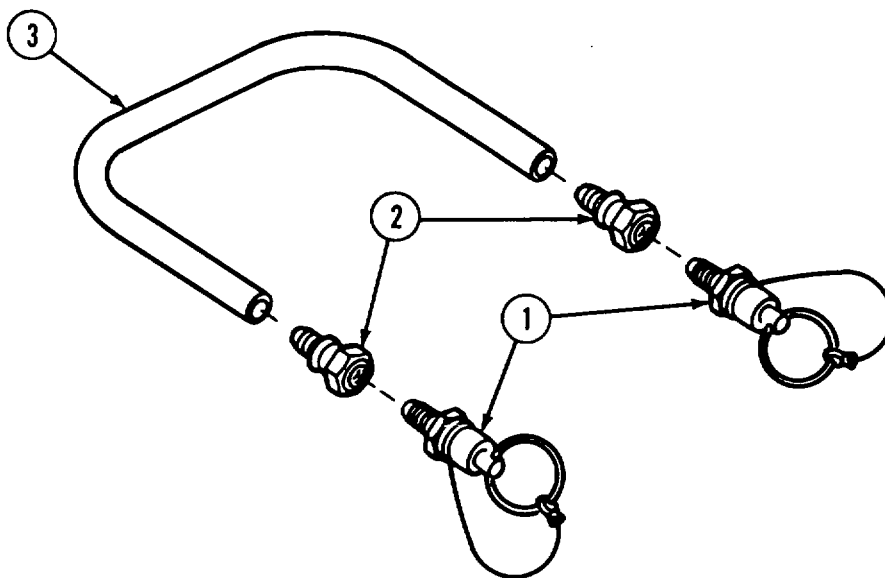

- a. Remove disconnect couplings (1) from adapters (2).
- b. Cut hydraulic hose (3) at adapter (2) and remove adapter.
- c. Fabricate new air hose.
- d. Replace adapters or disconnect couplings as required.
- e. Press adapters in hydraulic hose.
- f. Install disconnect couplings (1) on adapters (2).

2-13. OIL HOSE ASSEMBLY.

This task covers:

INITIAL SETUP

Facilities and Equipment.

Oil hose (fig. E-2, app E)

Equipment Condition

Oil hose removed from equipment (p 2-32).

Tools

General Mechanic's Tool Kit
SC 5180-90-N26

REPAIR

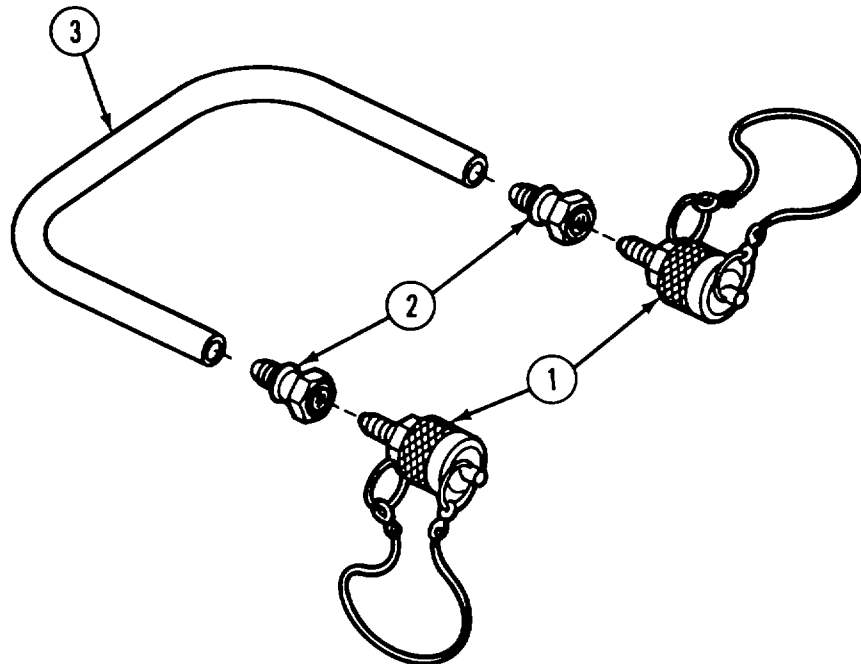

- a. Remove disconnect couplings (1) from adapters (2).
- b. Cut hydraulic hose (3) at adapter (2) and remove adapter.
- c. Fabricate new oil hose.
- d. Replace adapters or disconnect couplings as required.
- e. Press adapters in hydraulic hose.
- f. Install disconnect couplings (1) on adapters (2).

2-14. FUEL LID ASSEMBLY.

This task covers:

- a. Disassembly
- b. Repair

c. Reassembly

INITIAL SETUP

Tools

General Mechanic's Tool Kit
SC 5180-90-N26

Equipment Condition

Lid assembly removed from gas can (p 2-28).

Materials/Parts

Sealing compound (item 9, app D)

DISASSEMBLY

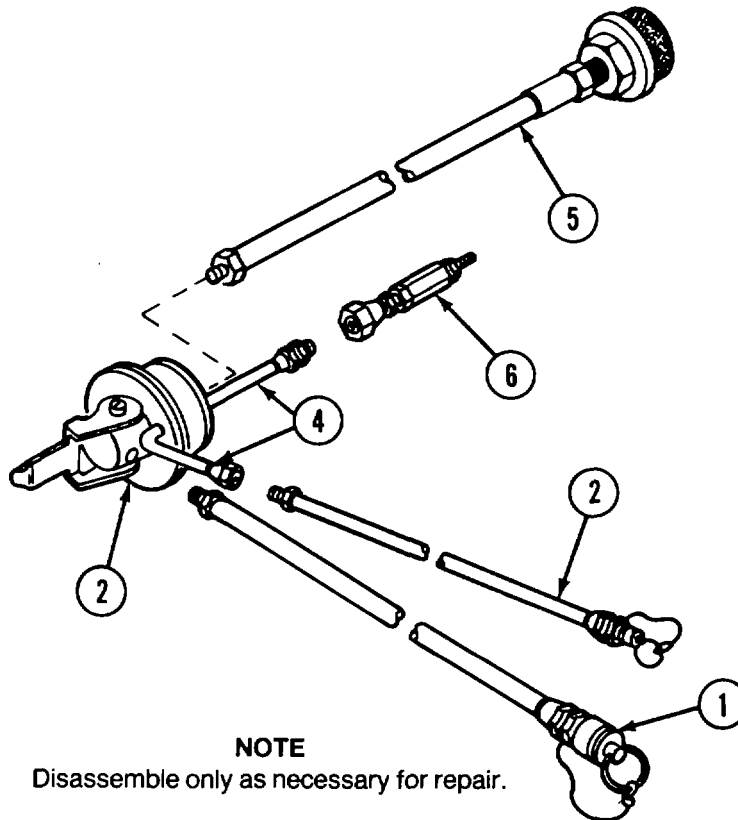

- a. Remove fuel supply hose assembly (1) from fuel adapter lid (2).
- b. Disconnect fuel return hose assembly (3) from return tube (4).
- c. Remove fuel hose assembly (5) from fuel adapter lid (2).
- d. Remove check valve assembly (6) from return tube (4).

REPAIR

- a. Fuel supply hose assembly (p 2-44).
- b. Fuel return hose assembly (p 2-43).
- c. Fuel hose assembly (p 2-42).
- d. Replace check valve assembly as required.

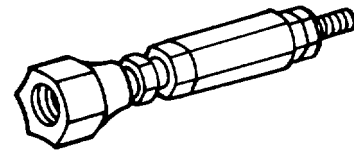

REASSEMBLY

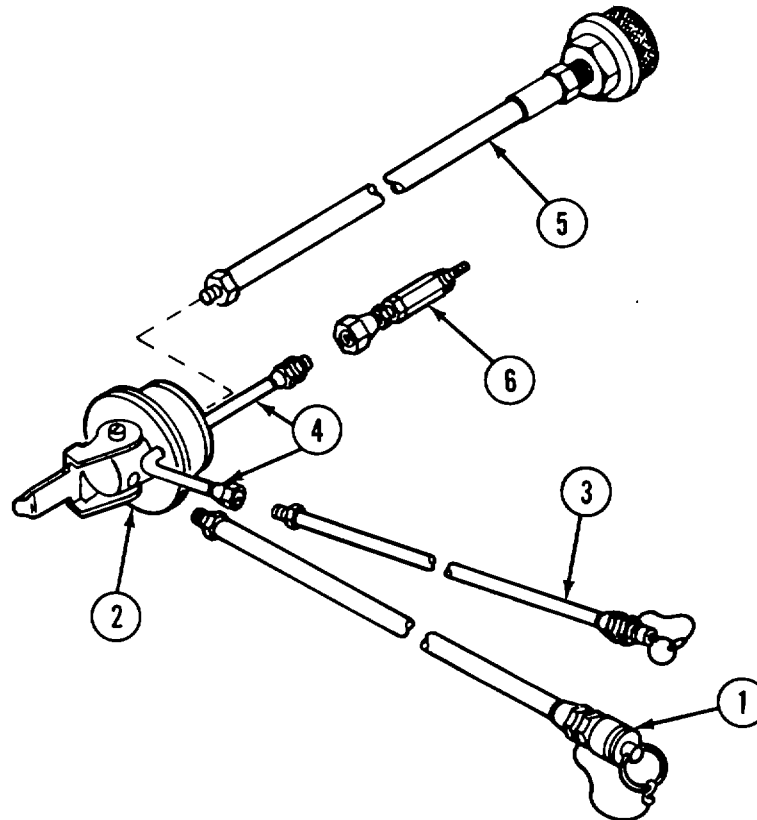

NOTE

Apply a sealing compound to threads of male pipe fittings before installing.

- a. Install fuel supply hose assembly (1) on fuel adapter lid (2).
- b. Connect fuel return hose assembly (3) to return tube (4).
- c. Install hose assembly (5) on fuel adapter lid (2).
- d. Install check valve assembly (6) on return tube (4).

2-15. FUEL HOSE ASSEMBLY.

This task covers repair.

INITIAL SETUP

Facilities and Equipment

Fuel hose (fig. E-3, app E)

Equipment Condition

Fuel hose assembly removed from fuel lid assembly (p 2-40).

Tools

General Mechanic's Tool Kit
SC 5180-90-N26

REPAIR

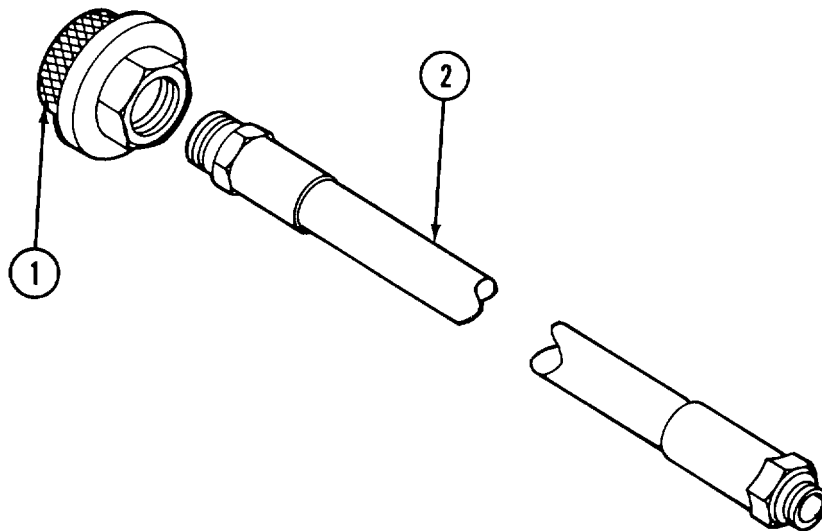

- a. Remove strainer (1) from hydraulic hose (2).
- b. Replace strainer or hose as required.
- c. Install strainer (1) on hose.

2-16. FUEL RETURN HOSE ASSEMBLY.

This task covers repair.

INITIAL SETUP*Facilities and Equipment*

Fuel return hose (fig. E-4, app E)

Equipment Condition

Hose removed from fuel lid assembly (p 2-40).

Tools

General Mechanic's Tool Kit

SC 5180-90-N26

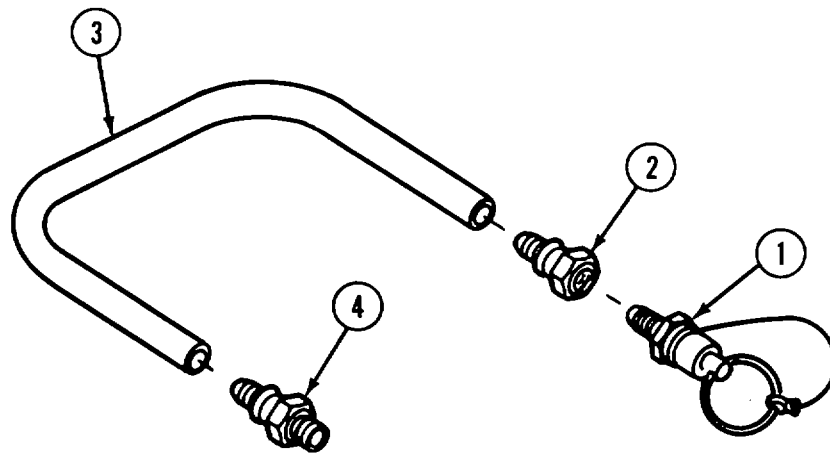
REPAIR

- a. Remove disconnect coupling (1) from adapter (2).
- b. Cut hydraulic hose (3) at adapters (2 and 4) and remove adapters.
- c. Fabricate new fuel return hose.
- d. Replace adapters or disconnect coupling as required.
- e. Press adapters (2 and 4) in hydraulic hose (3) and install disconnect coupling (1).

2-17. FUEL SUPPLY HOSE ASSEMBLY.

This task covers repair.

INITIAL SETUP*Facilities and Equipment*

Fuel supply hose (fig. E-5, app E)

Equipment Condition

Hose removed from fuel adapter lid (p 2-41).

Tools

General Mechanic's Tool Kit

SC-5180-90-N26

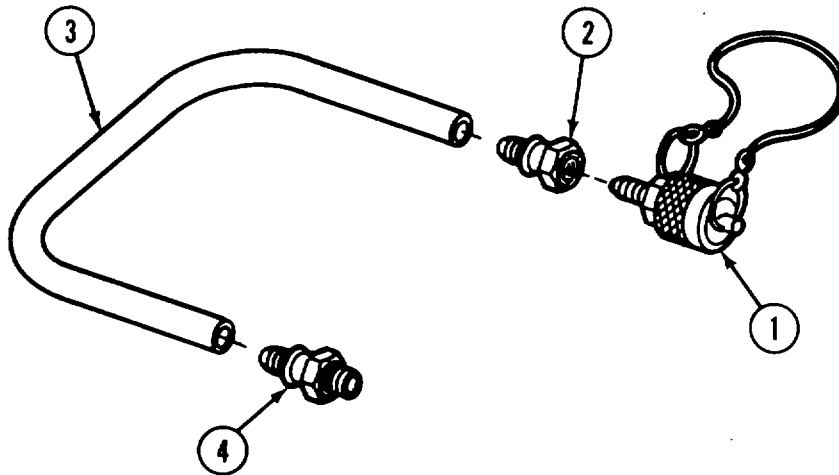
REPAIR

- a. Remove disconnect coupling (1) from adapter (2).
- b. Cut hydraulic hose (3) at adapters (2 and 4) and remove adapters.
- c. Fabricate new fuel supply hose.
- d. Replace adapters or disconnect coupling as required.
- e. Press adapters (2 and 4) in hydraulic hose (3) and install disconnect coupling (1).

Section V. M157 MAINTENANCE PROCEDURES

2-18. INTRODUCTION. This section contains the removal and installation procedures for the M157 smoke generator set components which are mounted by this kit.

Refer to TM 3-1040-279-12&P for repair of smoke generator set components.

2-19. SMOKE GENERATOR SET COMPONENTS.

This task covers replacement of:

- a. M54 Smoke Generators
- b. Control Panel Assembly
- c. Fog Oil Pump Assembly

- d. Air Compressor Assembly
- e. Fog Oil Tank Assembly

a. *M54 Smoke Generators.*

INITIAL SETUP

Tools

General Mechanic's Tool Kit
SC 5180-90-N26

Personnel Required

One mechanic
One assistant

**1
REMOVAL**

WARNING

Hot surfaces may be present if the generator has recently been operated. Allow sufficient time for cooling before handling or servicing.

NOTE

Removal and installation are the same for both generators.

- a. Set circuit breaker CB1 on control panel to OFF.
- b. Disconnect cable and hose assemblies (1) from cover assembly (2) on smoke generator (3).

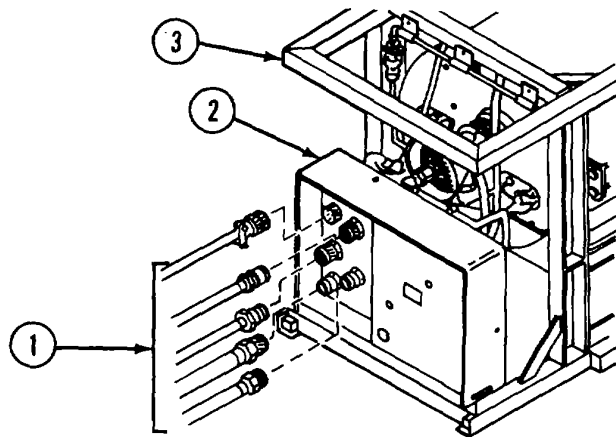

2-19. SMOKE GENERATOR SET COMPONENTS (CONT).

REMOVAL (CONT)

2

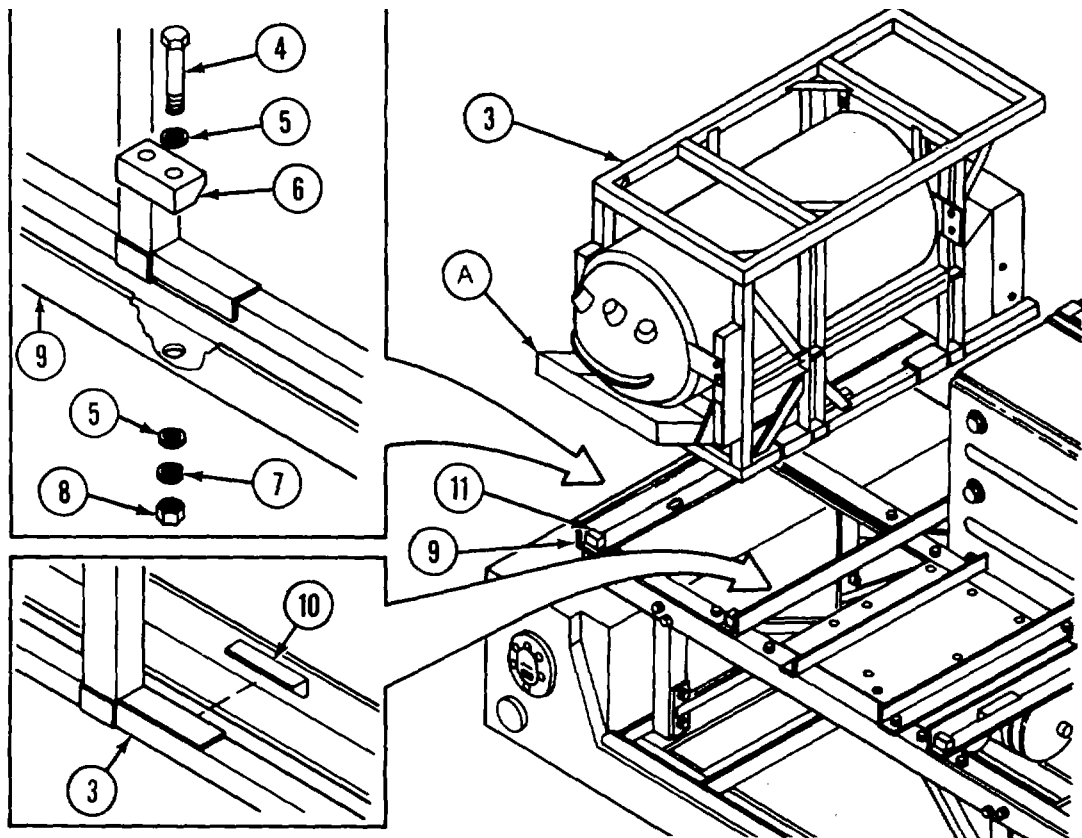

- a. Drain smoke generator drip pan (A). Remove two screws (4), four washers (5), two connecting links (6), two lockwashers (7) and two nuts (8) securing smoke generator (3) in generator bracket (9).

WARNING

Generator is heavy. To prevent personnel injury, use a hoist or four people to lift.

- b. Lift and remove smoke generator.

INSTALLATION

1

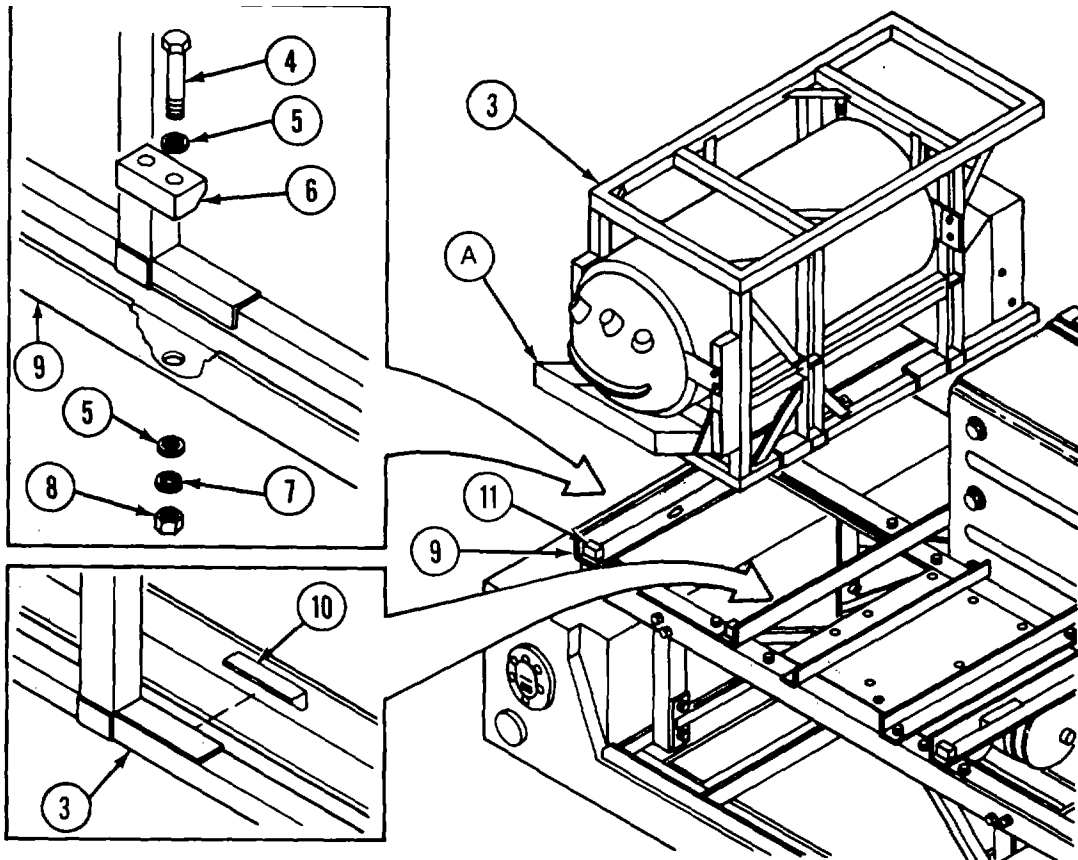

WARNING

Generator is heavy. To prevent personnel injury, use a hoist or four people to lift.

- a. Position smoke generator (3) in generator bracket (9) with frame of smoke generator (3) under lips (10) bracket and against stop blocks (11).
- b. Secure smoke generator (3) in generator bracket (9) with two screws (4), four washers (5), two connect links (6) two lockwashers (7), and two nuts (8).

2

Connect cable and hose assemblies (1) to cover assembly (2) on smoke generator. Refer to page 2-18 for connections.

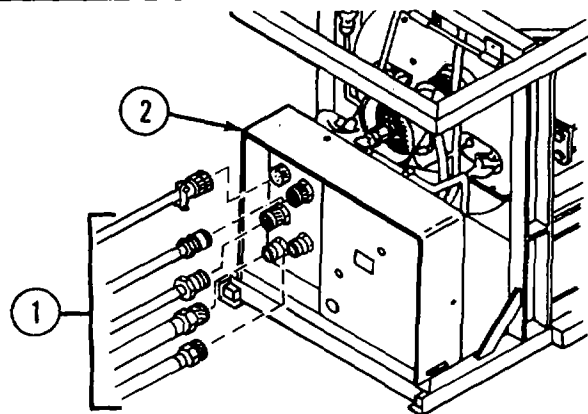

2-19. SMOKE GENERATOR SET COMPONENTS (CONT).

b. Control Panel Assembly.

INITIAL SETUP

Tools

General Mechanic's Tool Kit
SC 5180-90-N26

REMOVAL

1

Set circuit breaker CB1 (1) on control panel to OFF. Disconnect cable assemblies (2) from top of control panel assembly (3).

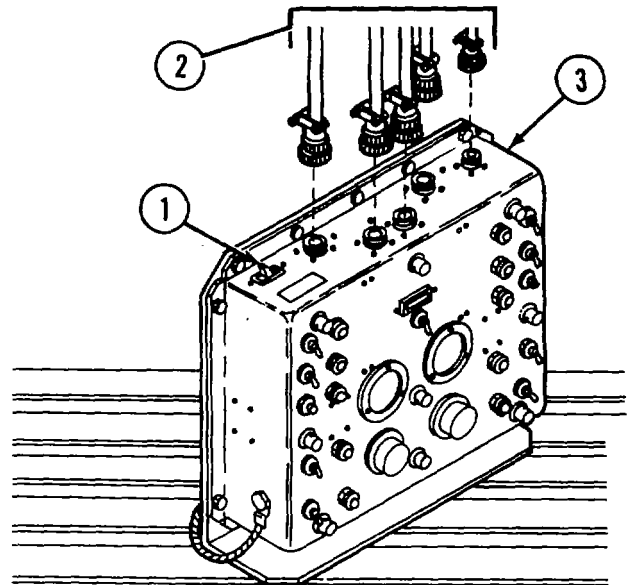

2

- a. Remove four screws (4), eight washers (5), and four nuts (6) securing control panel assembly (3) and ground strap (7) to mounting bracket (8).
- b. Remove control panel assembly.

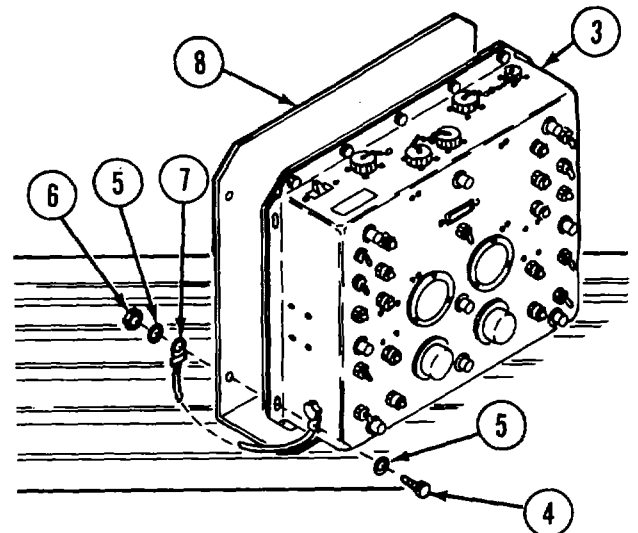

INSTALLATION

1

Install control panel assembly (3) with ground strap (7) on mounting bracket (8) with four screws (4), eight washers (5), and four nuts (6).

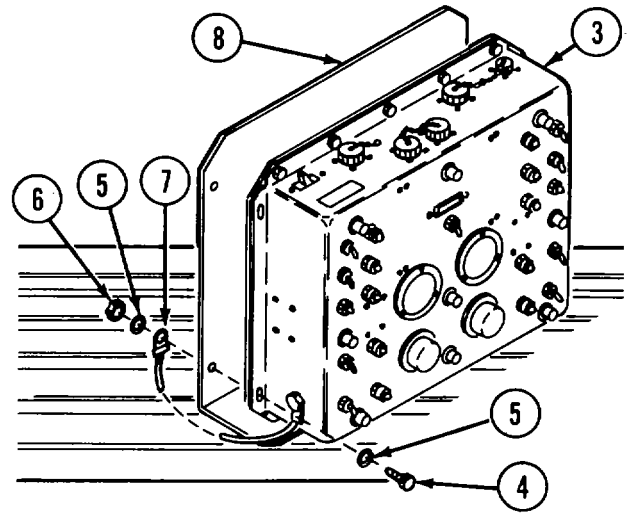

2

Connect cable assemblies (2) to control panel assembly (3). Refer to page 2-18 for connections.

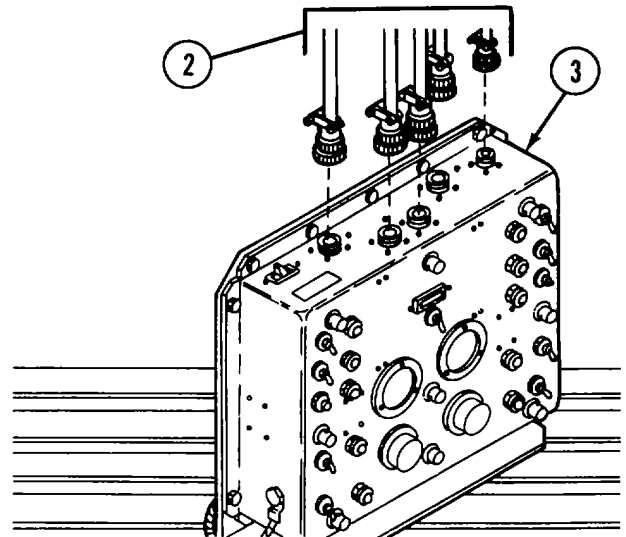

2-19. SMOKE GENERATOR SET COMPONENTS (CONT).

c. Fog Oil Pump Assembly.

INITIAL SETUP

Tools

- General Mechanic's Tool Kit
SC 5180-90-N26
- Automotive Shop Equipment
SC 4910-95-CL-A74:
Wrench, 1-7/16 in.
Drain pan

Personnel Required

- One mechanic
- One assistant

REMOVAL

1

- a. Disconnect hose assemblies (1) from quick disconnect fittings (2).
- b. Disconnect cable assembly (3) from connector 6J3 (4) on fog oil pump assembly (5).

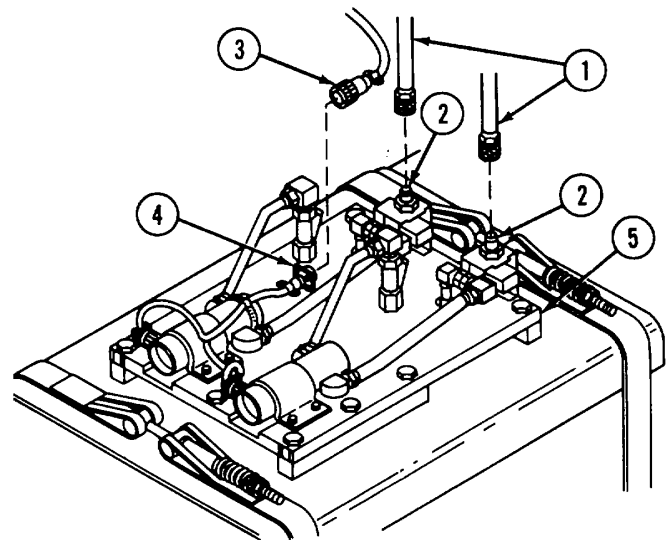

2

WARNING

Fog oil is very slippery. Clean up all spills immediately to prevent injury to personnel. Do not drain fog oil near open flames or while smoking.

NOTE

The following hoses may contain fog oil. Have a suitable container available.

- a. Disconnect hose assemblies (6) from strainer assemblies (7) and remove strainer assemblies from fog oil tank (8).
- b. Remove 12 screws (11), lockwashers (12), and washers (13). Lift and remove fog oil pump assembly (5) from fog oil tank (8).
- c. Remove bushing assemblies (9) from fog oil tank (8).

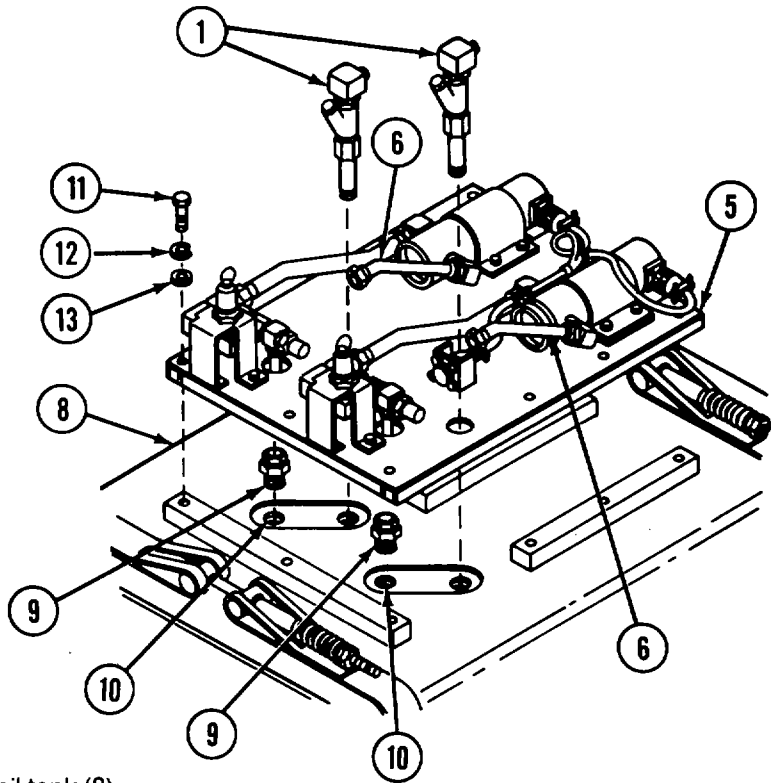

INSTALLATION

1

- a. Install bushing assemblies (9) in fog oil tank return ports (10).
- b. Position fog oil pump assembly (5) on fog oil tank (8) with return tubes (14) in bushing assemblies (9).
- c. Install strainer assemblies (7) in fog oil tank (8).
- d. Connect hose assemblies (6) to strainer assemblies (7).
- e. Secure fog oil pump assembly (5) to fog oil tank (8) with 12 screws (11), lockwashers (12), and washers (13).

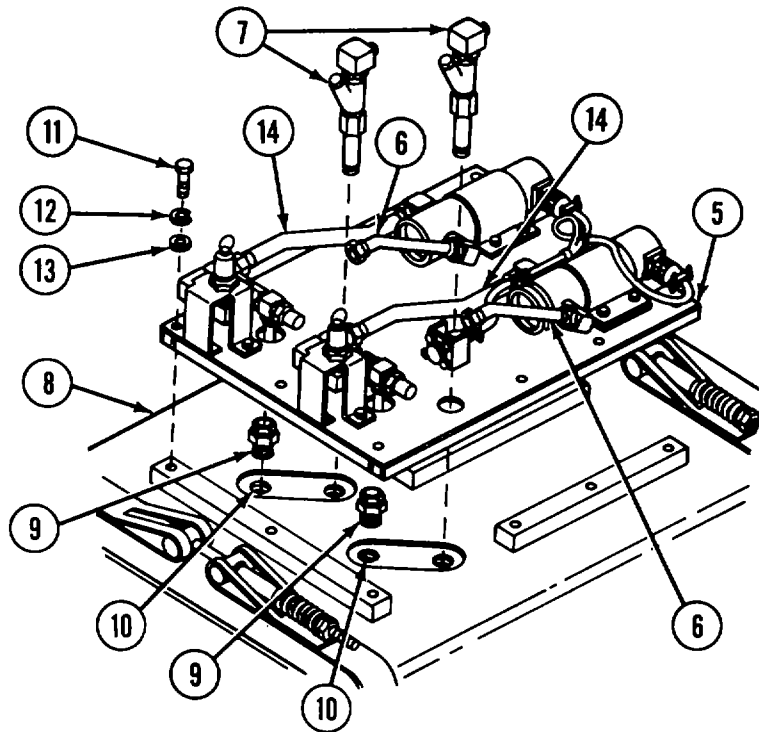

2-19. SMOKE GENERATOR SET COMPONENTS (CONT).

c. Fog Oil Pump Assembly (Cont).

INSTALLATION (CONT)

2

2

- a. Connect cable assembly (3) to connector 6J3 (4).
- b. Connect hose assemblies (1) to quick disconnect fittings (2).

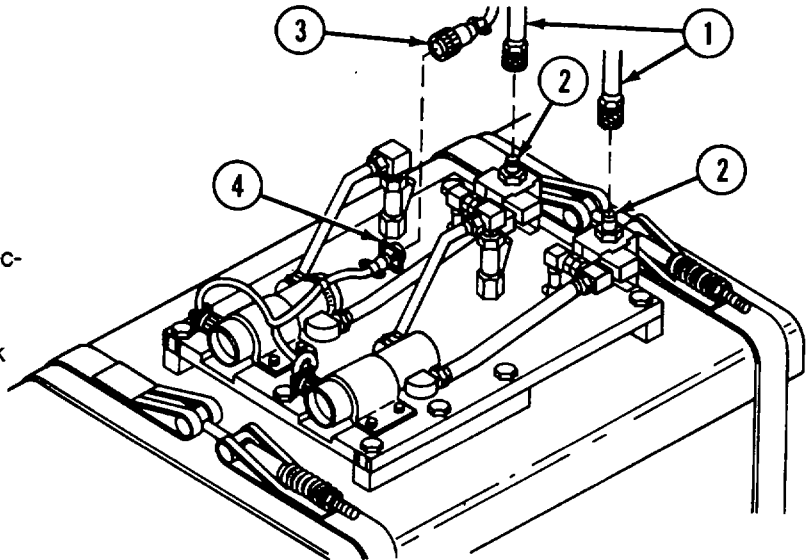

d. Air Compressor Assembly.

INITIAL SETUP

Tools

General Mechanic's Tool Kit
SC 5180-90-N26

Personnel Required

One mechanic
One assistant

REMOVAL

1

WARNING

Air compressor tank is pressurized to 63 psig. Bleed air from tank before attempting maintenance or disconnecting hoses. The bleed air may contain dirt particles. Keep face away from escaping air to avoid possible eye injury.

- a. Disconnect cable assembly (1) from connector 2J1 on air compressor assembly (2).
- b. Press control valve (3) on air compressor assembly and release tank pressure.
- c. Disconnect air hose assemblies (4) from quick-disconnect fittings (5) at each end of compressor tank.

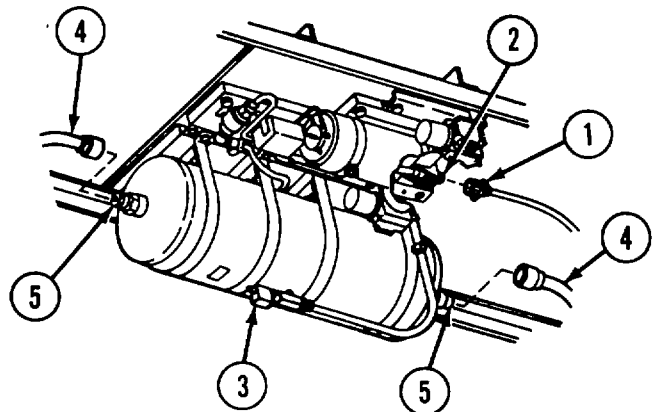

2

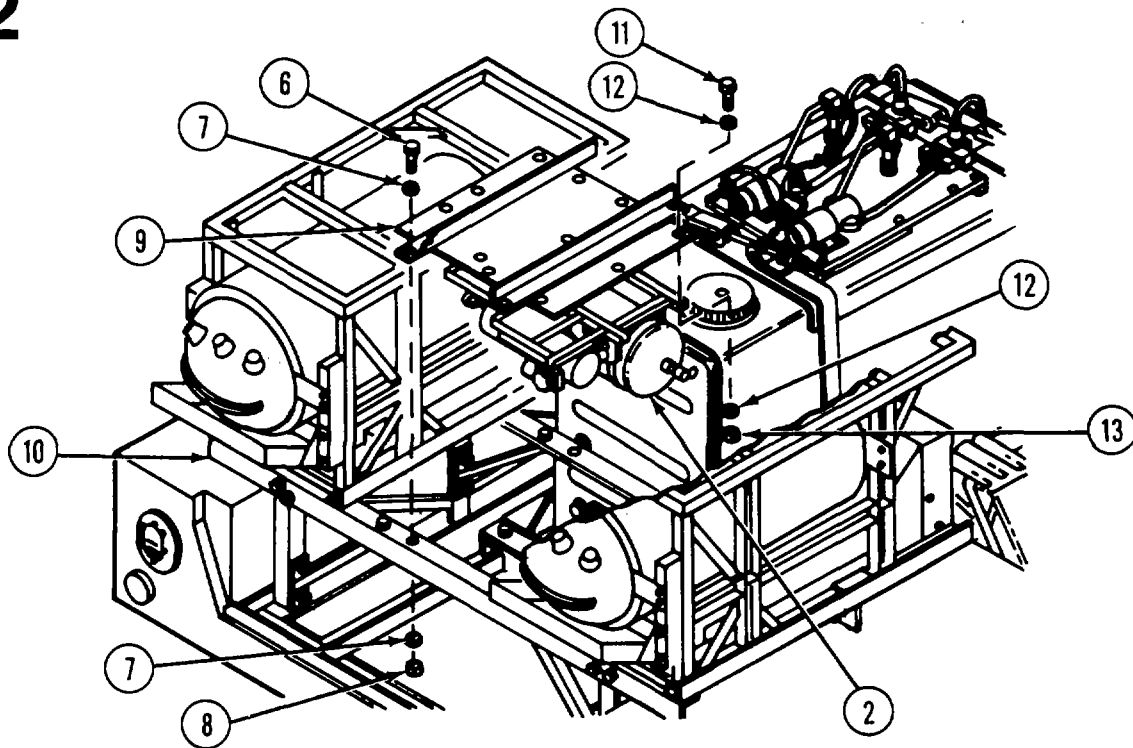

- a. Remove one of the smoke generators (p 2-45) and generator bracket (p 2-21).
- b. Remove four screws (6), eight washers (7), and four nuts (8) securing mounting plate (9) and air compressor assembly (2) to generator support angles (10) of frame assembly.

WARNING

Air compressor and mounting plate are heavy. To prevent personnel injury, use two people to lift.

- c. Remove mounting plate with air compressor assembly.
- d. Remove 11 screws (11), 22 washers (12), and 11 nuts (13) securing air compressor assembly (2) to mounting plate (9).

2-19. SMOKE GENERATOR SET COMPONENTS (CONT).

d. Air Compressor Assembly (Cont).

INSTALLATION

1

WARNING
Air compressor and mounting plate are heavy. To prevent personnel injury, use two people to lift.

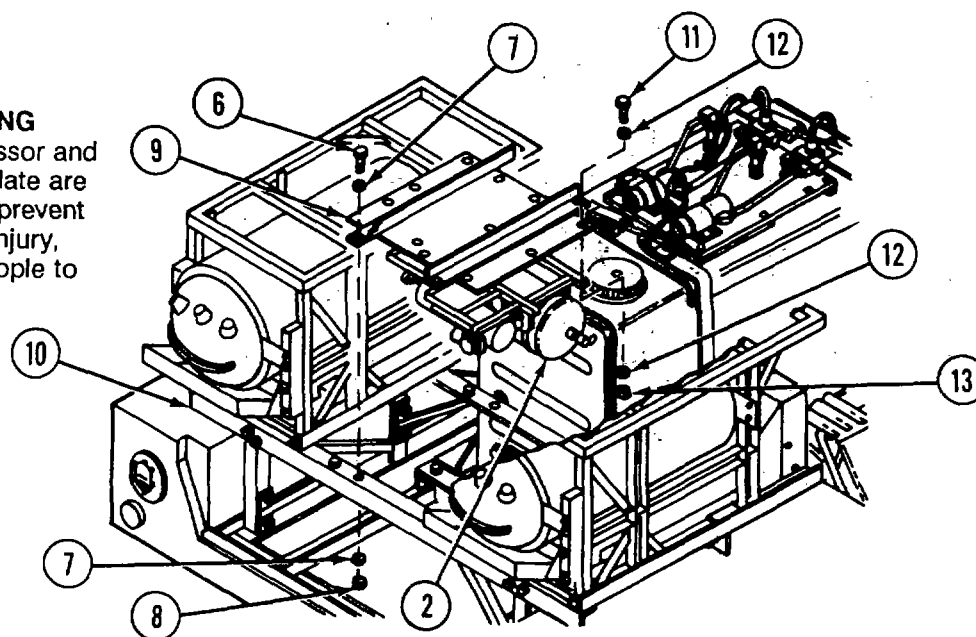

- a. Attach air compressor assembly (2) to mounting plate (9) with 11 screws (11), 22 washers (12), and 11 nuts (13).
- b. Position mounting plate (9) over mounting holes in generator support angles (10) with air compressor tank to front of vehicle.
- c. Secure mounting plate (9) to generator support angles (10) with four screws (6), eight washers,(7), and four nuts (8).

2

- a. Connect air hose assemblies (4) to quick-disconnect fittings (5) on air compressor tank.
- b. Connect cable assembly (1) to connector 2J1 on air compressor assembly (2).
- c. Reinstall generator bracket (p 2-21) and smoke generator (p 2-47).

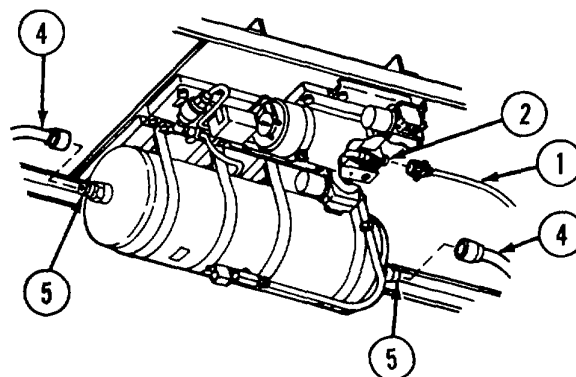

e. Fog Oil Tank Assembly.

INITIAL SETUP

Tools

- General Mechanic's Tool Kit SC 5180-90-N26
- Automotive Shop Equipment SC 4910-95-CL-A74:
 - Wrench, 1-7/16 in.
 - Drain pan

Materials/Parts

- Plastic strip (item 6, app D)

Facilities and Equipment

- Shop area with overhead chain hoist or 5-ton wrecker
- Drain hose (fig E-1, app E)

Personnel Required

- One mechanic
- One assistant

REMOVAL

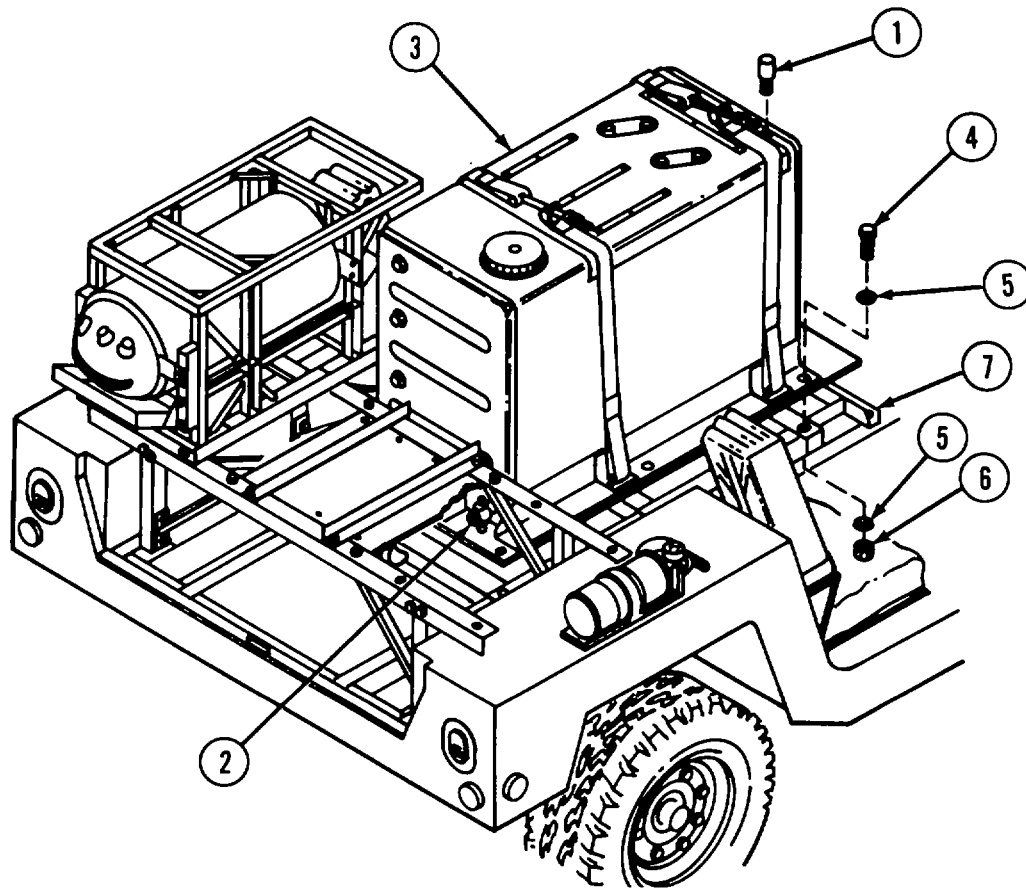

- a. Remove one of the smoke generators (p 2-45) and generator bracket (p 2-21).
- b. Remove fog oil pump assembly (p 2-50).
- c. Remove check valve (1).

WARNING

Fog oil is very slippery. Clean up all spills immediately to prevent injury to personnel. Do not drain fog oil near open flames or while smoking.

- d. Connect drain hose to plug valve (2) on fog oil tank (3) and drain tank into a suitable container.
- e. Remove 6 screws (4), 12 washers (5), and 6 nuts (6) securing fog oil tank assembly (3) to frame assembly (7). Remove fog oil tank assembly.

2-19. SMOKE GENERATOR SET COMPONENTS (CONT).

e. Fog Oil Tank Assembly (Cont).

INSTALLATION

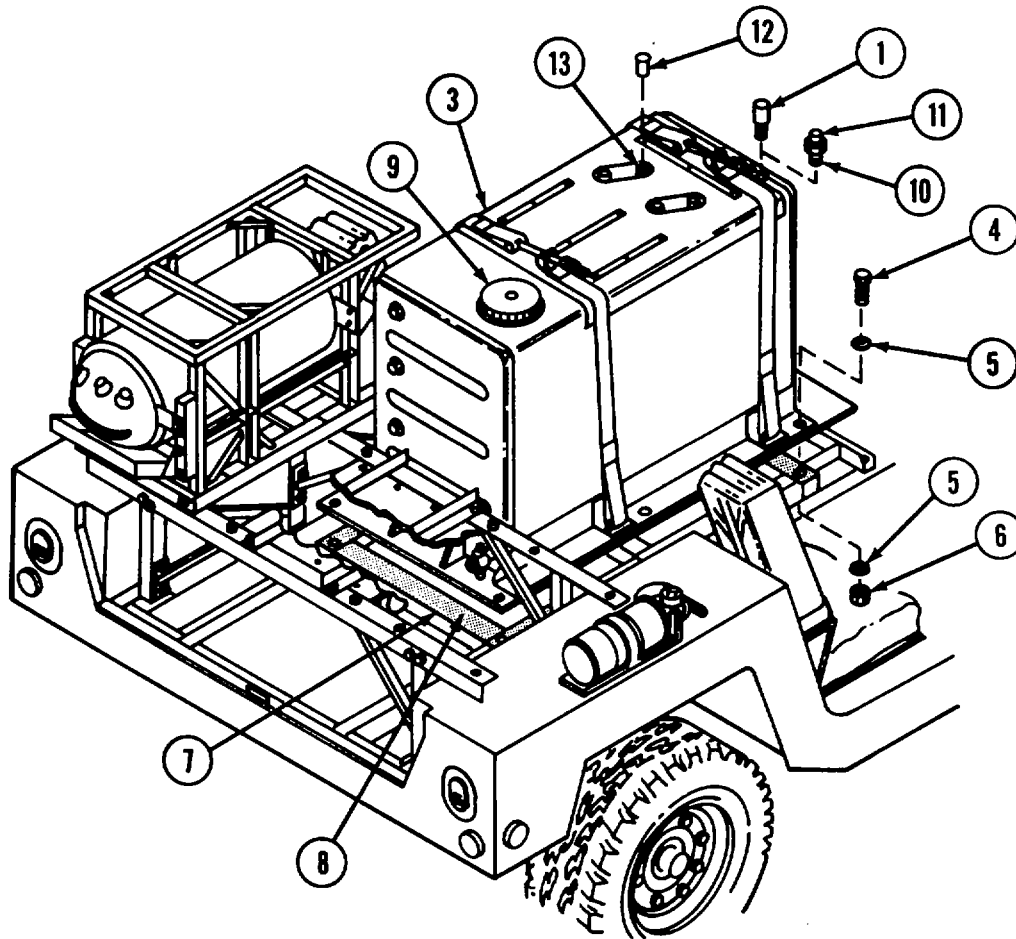

- Apply a layer of plastic strip (8) to fog oil tank assembly mounting surface on frame assembly (7). Cut out six mounting holes in plastic strip with knife.
- Position fog oil tank assembly (3) on frame assembly with fuel cap (9) to rear of vehicle. Secure fog oil tank assembly with 6 screws (4), 12 washers (5), and 6 nuts (6).
- Remove adapter (10) and cap (11) from fog oil tank and install check valve (1).
- Remove protective plugs (12) from fog oil tank supply and return ports (13) and install fog oil pump assembly (p 2-51).
- Install generator bracket (p 2-21) and smoke generator (p 2-47).

Section VI. PREPARATION FOR STORAGE OR SHIPMENT

2-20. SCOPE. This section provides guidance and instructions for administrative storage of equipment. No special instructions for preservation or shipping are required.

2-21. PREPARATION FOR STORAGE.

- a. Store mounting kit with vehicle on which it is mounted.
- b. Perform next scheduled preventive maintenance checks and services (p 2-10). Correct all shortcomings and deficiencies. Check that all modification work orders (MWO's) have been applied.
- c. Drain fog oil from fog oil tank.
- d. Remove fire extinguishers and store in a secure area to prevent theft.

e. Remove fuel lid assemblies from 5-gallon gas cans and store gas cans in area approved by local fire regulations.

2-22. STORAGE.

- a. Perform monthly walk-around visual inspection of mounting kit. Inspect for corrosion or other deterioration and missing or damaged parts.
- b. Record and report maintenance actions in accordance with DA PAM 738-750.

2-23. REMOVAL FROM STORAGE.

- a. Install fire extinguishers and 5-gallon gas cans in mounting brackets.
- b. Resume normal maintenance of mounting kit.

2-57/(2-58 blank)

**APPENDIX A
REFERENCES**

A-1. TECHNICAL MANUALS.

- TM 3-1040-279-12&P..... Operator's and Organizational Maintenance Manual: Generator Set Smoke, Mechanical, Pulse Jet, M157 (1040-01-206-0147).
- TM 9-2320-280-20..... Organizational Maintenance-Truck, Utility: Cargo/Troop Carrier, 1-1/4 Ton, 4X4, M998 (2320-01-107-7155).
- TM 43-0139 Painting Instructions for Field Use.

A-2. PAMPHLETS.

- DA PAM 25-30..... Consolidated Index of Army Publications and Blank Forms.
- DA PAM 738-750..... The Army Maintenance Management System (TAMMS).

A-3. SUPPLY CATALOGS.

- SC 4910-95-CL-A74..... Shop Equipment, Automotive Maintenance and Repair: Organizational Maintenance, Common No. 1, Less Power (NSN 4910-00-754-0654) (W32593) and MAP only (NSN 4910-00-919-0098).
- SC 5180-90-N26..... Sets, Kits, and Outfits for Tool Kit, General Mechanic's: Automotive (NSN 5180-00-177-7033).

A-4. COMMON TABLES OF ALLOWANCES.

- CTA 8-100 Army Medical Department Equipment Expendable/Durable Items.
- CTA 50-970 Expendable/Durable Items (Except: Medical Class V, Repair Parts and Heraldic Items).

A-5. BLANK FORMS.

- DA Form 2028 Recommended Changes to Publications and Blank Forms.
- DA Form 2028-2 Recommended Changes to Equipment Technical Publications.
- DA Form 2404 Equipment Inspection and Maintenance Worksheet.
- SF 364..... Report of Discrepancy (ROD).
- SF 368..... Product Quality Deficiency Report (Category II).

APPENDIX B MAINTENANCE ALLOCATION CHART

Section I. INTRODUCTION

B-1. THE ARMY MAINTENANCE SYSTEM MAC.

a. This introduction (section 1) provides a general explanation of all maintenance and repair functions authorized at various maintenance levels under the standard Army Maintenance System concept.

b. The Maintenance Allocation Chart (MAC) in section II designates overall authority and responsibility for the performance of maintenance functions on the identified end item or component. The application of the maintenance functions to the end item or component will be consistent with the capacities and capabilities of the designated maintenance levels, which are shown on the MAC in column (4) as:

UNIT, which includes two subcolumns, C (operator/crew) and O (unit maintenance)

INTERMEDIATE, which includes two subcolumns, F (Intermediate Direct Support) and H (Intermediate General Support)

DEPOT, which includes a D (Depot) subcolumn

c. Section III lists the tools and test equipment (both special tools and common tool sets) required for each maintenance function as referenced from section II.

d. Section IV contains supplemental instructions and explanatory notes for a particular maintenance function.

B-2. MAINTENANCE FUNCTIONS. Maintenance functions will be limited to and defined as follows:

a. *Inspect.* To determine the serviceability of an item by comparing its physical, mechanical, and/or electrical characteristics with established standards through examination (e.g., by sight, sound, or feel).

b. *Test.* To verify serviceability by measuring the mechanical, pneumatic, hydraulic, or electrical characteristics of an item and comparing those characteristics with prescribed standards.

c. *Service.* Operations required periodically to keep an item in proper operating condition, i.e., to clean

(includes decontaminate, when required), to preserve, to drain, to paint, or to replenish fuel, lubricants, chemical fluids, or gases.

d. *Adjust.* To maintain or regulate, within prescribed limits, by bringing into proper or exact position, or by setting the operating characteristics to specified parameters.

e. *Align.* To adjust specified variable elements of an item to bring about optimum or desired performance.

f. *Calibrate.* To determine and cause corrections to be made or to be adjusted on instruments or test, measuring and diagnostic equipments used in precision measurement. Consists of comparisons of two instruments, one of which is a certified standard of known accuracy, to detect and adjust any discrepancy in the accuracy of the instrument being compared.

g. *Remove/install.* To remove and install the same item when required to perform service or other maintenance functions. Install may be the act of emplacing, seating, or fixing into position a spare, repair part, or module (component or assembly) in a manner to allow the proper functioning of an equipment or system.

h. *Replace.* To remove an unserviceable item and install a serviceable counterpart in its place. "Replace" is authorized by the MAC and is shown as the 3d position code of the SMR code.

i. *Repair.* The application of maintenance services including fault location/ troubleshooting, removal/ installation, and disassembly/assembly procedures, and maintenance actions to identify troubles and restore serviceability to an item by correcting specific damage, fault, malfunction, or failure in a part, subassembly, module (component or assembly), end item, or system.

B-2. MAINTENANCE FUNCTIONS (CONT).

j. *Overhaul.* That maintenance effort (service/action) prescribed to restore an item to a completely serviceable/operational condition as required by maintenance standards in appropriate technical publications (i.e., DMWR). Overhaul is normally the highest degree of maintenance performed by the Army. Overhaul does not normally return an item to like new condition.

k. *Rebuild.* Consists of those services/actions necessary for the restoration of unserviceable equipment to a like new condition in accordance with original manufacturing standards. Rebuild is the highest degree of materiel maintenance applied to Army equipment. The rebuild operation includes the act of returning to zero those age measurements (hours/miles, etc.) considered in classifying Army equipment/components.

B-3. EXPLANATION OF COLUMNS IN THE MAC, SECTION II.

a. *Column (1), Group Number.* Column (1) lists functional group code numbers, the purpose of which is to identify maintenance significant components, assemblies, subassemblies, and modules with the next higher assembly.

b. *Column (2), Component/Assembly.* Column (2) contains the names of components, assemblies, subassemblies, and modules for which maintenance is authorized.

c. *Column (3), Maintenance Function.* Column (3) lists the functions to be performed on the item listed in column (2).

d. *Column (4), Maintenance Level.* Column (4) specifies, by the listing of a work time figure in the appropriate subcolumn(s), the level of maintenance authorized to perform the function listed in column (3). This figure represents the active time required to perform that maintenance function at the indicated level of maintenance. If the number or complexity of the tasks within the listed maintenance function vary at different maintenance level, appropriate work time figures will be shown for each level. The work time figure represents the average time required to restore an item (assembly, subassembly, component, module, end item, or system) to a serviceable condition under typical field operating conditions. This time includes preparation time (including any necessary disassembly/assembly time), troubleshooting/fault location time, and quality assurance/quality control time

in addition to the time required to perform the specific tasks identified for the maintenance functions authorized in the maintenance allocation chart. The symbol designations for the various maintenance levels are as follows:

- C..... Operator or Crew
- O..... Unit Maintenance
- F..... Intermediate Direct Support Maintenance
- H..... Intermediate General Support Maintenance
- L..... Specialized Repair Activity (SRA)
- D..... Depot Maintenance

e. *Column (5), Tools and Equipment.* Column (5) specifies, by code, those common tool sets (not individual tools) and special tools, TMDE, and support equipment required to perform the designated function.

f. *Column (6), Remarks.* This column shall, when applicable, contain a letter code, in alphabetic order, which shall be keyed to the remarks contained in section IV.

B-4. EXPLANATION OF COLUMNS IN TOOL AND TEST EQUIPMENT REQUIREMENTS, SECTION III.

a. *Column (1), Reference Code.* The tool and test equipment reference code correlates with a code used in the MAC, Section II, column (5).

b. *Column (2), Maintenance Level.* The lowest level of maintenance authorized to use the tool or test equipment.

c. *Column (3), Nomenclature.* Name or identification of the tool or test equipment.

d. *Column (4), National Stock Number.* The National stock number of the tool or test equipment.

e. *Column (5), Tool Number.* The manufacturer's part number.

B-5. EXPLANATION OF COLUMNS IN REMARKS, SECTION IV.

a. *Column (1), Reference Code.* The code recorded in column (6), Section II.

b. *Column (2), Remarks.* This column lists information pertinent to the maintenance function being performed as indicated in the MAC, Section II.

Section II. MAINTENANCE ALLOCATION CHART

(1) GROUP NUMBER	(2) COMPONENT/ ASSEMBLY	(3) MAINTENANCE FUNCTION	(4) MAINTENANCE LEVEL					(5) TOOLS AND EQUIPMENT	(6) REMARKS
			UNIT		INTERMEDIATE		DEPOT		
			C	O	F	H	D		
00	M284 SMOKE GENERATOR MOUNTING KIT	Inspect		.5				1,2,3,4	
		Remove/ Install		6.0					
		Repair		.4					1,2
01	GENERATOR BRACKET ASSEMBLY (RIGHT)	Replace		.4				1	
		Repair		.2					
02	GENERATOR BRACKET ASSEMBLY (LEFT)	Replace		.4				1	
		Repair		.2					
03	FRAME ASSEMBLY	Replace		4.0				1,4	
		Repair		.3					1
04	AIR HOSE ASSEMBLY	Remove/ Install		.1				1	
		Repair		.1					
0401	Hose Assembly	Repair		.3				1	
05	OIL HOSE ASSEMBLY	Remove/ Install		.1				1	
		Repair		.1					
0501	Hose Assembly	Repair		.3				1	
06	FUEL LID ASSEMBLY	Inspect		.1				1	
		Replace		.1					
		Repair		.2					
0601	Fuel Hose Assembly	Replace		.1				1 1	
		Repair		.1					
0602	Fuel Return Hose Assembly	Remove/ Install		.1				1 1	
		Repair		.1					
060201	Hose Assembly	Repair		.1				1	

(1) GROUP NUMBER	(2) COMPONENT/ ASSEMBLY	(3) MAINTENANCE FUNCTION	(4) MAINTENANCE LEVEL					(5) TOOLS AND EQUIPMENT	(6) REMARKS
			UNIT		INTERMEDIATE		DEPOT		
			C	O	F	H	D		
0603	Fuel Supply Hose Assembly	Remove/ Install		.1				1	
		Repair		.1				1	
060301	Hose Assembly	Repair		.1				1	

**Section III. TOOLS AND TEST EQUIPMENT REQUIREMENTS
FOR
M284 GENERATOR MOUNTING KIT**

(1) Tool or Test Equipment Ref Code	(2) Maintenance Category	(3) Nomenclature	(4) National/Stock Number (NSN)	(5) Tool Number
1	O	TOOL KIT, GENERAL MECHANIC'S	5180-00-177-7033	SC 5180-90-CL-N26
2	O	SHOP EQUIPMENT AUTOMOTIVE, COMMON NO. 1	4910-00-754-0654	SC 4910-95CLA74
3	O	SAW SET, HOLE	3455-00-684-3918	GGG-S-66
4	O	5-TON WRECKER OR CHAIN HOIST		

Section IV. REMARKS

Not Applicable

**APPENDIX C
UNIT MAINTENANCE
REPAIR PARTS AND SPECIAL TOOLS LIST**

Section I. INTRODUCTION

C-1. SCOPE. This RPSTL lists and authorizes spares and repair parts; special tools; special test, measurement, and diagnostic equipment (TMDE); and other special support equipment required for performance of unit maintenance of the mounting kit. It authorizes the requisitioning, issue, and disposition of spares, repair parts and special tools indicated by the Source, Maintenance and Recoverability (SMR) codes.

C-2. GENERAL. In addition to Section I, Introduction, this Repair Parts and Special Tools List is divided into the following sections:

a. *Section II. Repair Parts List.* A list of spares and repair parts authorized by this RPSTL for use in the performance of maintenance. The list also includes parts which must be removed for replacement of the authorized parts. Parts lists are composed of functional groups in ascending alphanumeric sequence, with the parts in each group listed in ascending figure and item number sequence. Bulk materials are listed by item name in FIG. BULK at the end of the section. Repair parts kits are listed separately in their own functional group within Section II. Repair parts for repairable special tools are also listed in this section.

b. *Section III. Special Tools List.* Not applicable.

c. *Section IV. Cross-Reference Indexes.* A list, in National item identification number (NIIN) sequence; of all National stock numbered items appearing in the listings, followed by a list in alphanumeric sequence of all part numbers appearing in the listings. National stock numbers and part numbers are cross-referenced to each illustration figure and item number appearance. This figure and item number index lists figure and item numbers in alphanumeric sequence and cross-references NSN, FSCM and part numbers.

C-3. EXPLANATION OF COLUMNS (SECTIONS II AND III).

a. *ITEM NO. (Column (1)).* Indicates the number used to identify items called out in the illustration.

b. *SMR CODE (Column (2)).* The Source, Maintenance, and Recoverability (SMR) code is a 5-position code containing supply/requisitioning information, maintenance level authorization criteria, and disposition instruction, as shown in the following breakout:

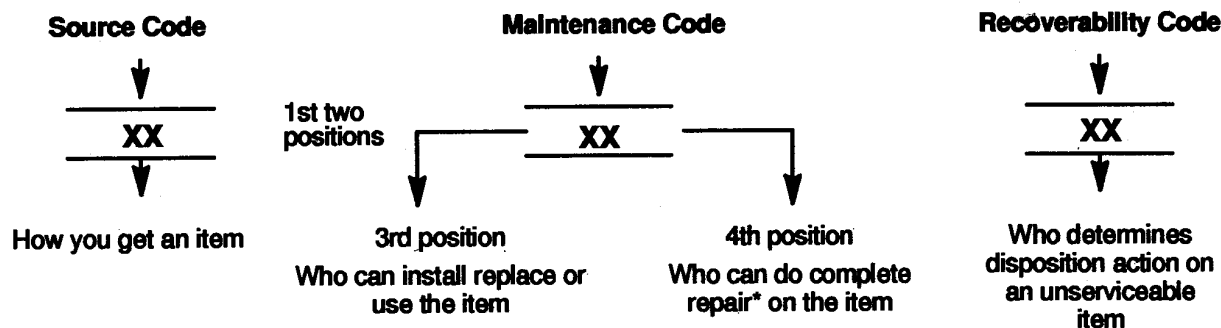

*Complete Repair: Maintenance capacity, capability, and authority to perform all corrective maintenance tasks of the "Repair" function in a use/user environment in order to restore serviceability to a failed item.

C-3. EXPLANATION OF COLUMNS (SECTION II AND III) (CONT).

(1) Source code. The source code tells you how to get an item needed for maintenance, repair, or overhaul of an end item/equipment. Explanations of source codes follow:

Code	Explanation
PA PB PC** PD PE PF PG	<p>Stocked items; use the applicable NSN to request/requisition items with these source codes. They are authorized to the category indicated by the code entered in the 3rd position of the SMR code.</p> <p>**NOTE : Items coded PC are subject to deterioration.</p>
KD KF KB	<p>Items with these codes are not to be requested/requisitioned individually. They are part of a kit which is authorized to the maintenance category indicated in the 3rd position of the SMR code. The complete kit must be requisitioned and applied.</p>
MO (Made at org AVUM level) MF (Made at DS/AVUM level) MH (Made at GS level) ML (Made at Specialized Repair Activity (SRA)) MD (Made at Depot)	<p>Items with these codes are not to be requested/requisitioned individually. They must be made from bulk material which is identified by the part number in the DESCRIPTION and USABLE ON CODE (UOC) column and listed in the Bulk Material group of the repair parts list in the RPSTL. If the item is authorized to you by the 3rd position code of the SMR code, but the source code indicates it is made at a higher level, order the item from the higher level of maintenance.</p>
PA PB PC** PD PE PF PG	<p>Stocked items; use the applicable NSN to request/requisition items with these source codes. They are authorized to the level indicated by the code entered in the 3d position of the SMR code.</p> <p>**NOTE: Items coded PC are subject to deterioration.</p>
KD KF KB	<p>Items with these codes are not to be requested/requisitioned individually. They are part of a kit which is authorized to the maintenance level indicated in the 3d position of the SMR code. The complete kit must be requisitioned and applied.</p>
AO (Assembled by org AVUM Level) AF (Assembled by DS/AVUM Level) AH (Assembled by GS Category) AL (Assembled by SRA) AD (Assembled by Depot)	<p>Items with these codes are not to be requested/requisitioned individually. The parts that make up the assembled item must be requisitioned or fabricated and assembled at the level of maintenance indicated by the source code. If the 3rd position code of the SMR code, authorizes you to replace the item, but the source code indicates the items are assembled at a higher level, order the item from the higher level of maintenance.</p>
XA -	Do not requisition an "XA"-coded item. Order its next higher assembly. (Also, refer to the NOTE below.)
XB -	If an "XB" item is not available from salvage, order it using the CAGE Code and part number given.
XC -	Installation drawing, diagram, instruction sheet, field service drawing, that is identified by manufacturer's part number.
XD -	Item is not stocked. Order an "XD"-coded item through normal supply channels using the CAGE Code and part number given, if no NSN is available.

C-3. EXPLANATION OF COLUMNS (SECTION II AND III) (CONT).

NOTE

Cannibalization or controlled exchange, when authorized, may be used as a source of supply for items with the above source codes, except for those source coded "XA" or those aircraft support items restricted by requirements of AR 750-1

(2) Maintenance Code. Maintenance codes tell you the level(s) of maintenance authorized to USE and REPAIR support items. The maintenance codes are entered in the third and fourth positions of the SMR code as follows:

(a) The maintenance code entered in the third position tells you the lowest maintenance level authorized to remove, replace, and use an item. The maintenance code entered in the third position will indicate authorization to the following levels of maintenance.

Code	Application/Explanation
C -	Crew or operator maintenance done within unit/AVUM maintenance.
O -	Unit level VAVUM maintenance can remove, replace, and use the item.
F -	Direct support/AVIM maintenance can remove, replace, and use the item.
H -	General support maintenance can remove, replace, and use the item.
L -	Specialized repair activity can remove, replace, and use the item.
D -	Depot can remove, replace, and use the item.

(b) The maintenance code entered in the fourth position tells whether or not the item is to be repaired and identifies the lowest maintenance level with the capability to do complete repair (i.e., perform all authorized repair functions). This position will contain one of the following maintenance codes.

NOTE

Some limited repair may be done on an item at a lower level of maintenance, if authorized by the Maintenance Allocation Chart (MAC) and SMR codes.

This position will contain one of the following maintenance codes:

Code	Application/Explanation
O -	Unit VAVUM is the lowest level that can do complete repair of the item.
F -	Direct support VAVIM is the lowest level that can do complete repair of the item.
H -	General Support is the lowest level that can do complete repair of the item.
L -	Specialized repair activity is the lowest level that can do complete repair of the item.
D -	Depot is the lowest level that can do complete repair of the item.
Z -	Nonreparable. No repair is authorized.
B -	No repair is authorized. No parts or special tools are authorized for the maintenance of a "B" coded item. However, the item may be reconditioned by adjusting, lubricating, etc., at the user level.

C-3. EXPLANATION OF COLUMNS (SECTION II AND III) (CONT).

(3) Recoverability Code. Recoverability codes are assigned to items to indicate the disposition action on unserviceable items. The recoverability code is entered in the fifth position of the SMR Code as follows:

Recoverability Codes	Application/Explanation
Z -	Nonreparable item. When unserviceable, condemn and dispose of the item at the level of maintenance shown in 3rd position of SMR Code.
O -	Reparable item. When not economically repairable, condemn and dispose of the item at unit or AVUM level.
F -	Reparable item. When uneconomically repairable, condemn and dispose of the item at the direct support or AVIM level.
H -	Reparable item. When uneconomically repairable, condemn and dispose of the item at the general support level.
D -	Reparable item. When beyond lower level repair capability, return to depot. Condemnation and disposal of item not authorized below depot level.
L -	Reparable item. Condemnation and disposal not authorized below specialized repair activity (SRA).
A -	Item requires special handling or condemnation procedures because of specific reasons (e.g., precious metal content, high dollar value, critical material, or hazardous material). Refer to appropriate manuals/directives for specific instructions.

c. *FSCM (Column (3)).* The Federal Supply Code for Manufacturer (FSCM) is a 5-digit numeric code which is used to identify the manufacturer, distributor, or Government agency, etc., that supplies the item.

d. *PART NUMBER (Column (4)).* Indicates the primary number used by the manufacturer (individual, company, firm, corporation, or Government activity), which controls the design and characteristics of the item by means of its engineering drawings, specifications standards, and inspection requirements to identify an item or range of items.

NOTE

When you use an NSN to requisition an item, the item you receive may have a different part number from the part ordered.

e. *DESCRIPTION AND USABLE ON CODE (UOC) (Column (5)).* This column includes the following information:

- (1) The Federal item name and, when required, a minimum description to identify the item.
- (2) Items that are included in kits and sets are listed below the name of the kit or set.
- (3) Spare/repair parts that make up an assembled item are listed immediately following the assembled item line entry.
- (4) Part numbers for bulk materials are referenced in this column in the line item entry for the item to be manufactured/fabricated.
- (5) When the item is not used with all serial numbers of the same model, the effective serial numbers are shown on the last lines of the description (before UOC).
- (6) The usable on code, when applicable (see paragraph C-5, special information).
- (7) The statement "END OF FIGURE" appears just below the last item description in Column (5) for a given figure in both Section II and Section III.

f. *QTY (Column (6)).* The QTY (quantity per figure column) indicates the quantity of the item used in the breakout shown on the illustration figure, which is prepared for a functional group, subfunctional group, or an assembly. A "V" appearing in this column in lieu of a quantity indicates that the quantity is variable and the quantity may vary from application to application.

C-4. EXPLANATION OF COLUMNS (SECTION IV).a. *NATIONAL STOCK NUMBER (NSN) INDEX.*

(1) STOCK NUMBER column. This column lists the NSN by National item identification number.

(NIIN) sequence The NIIN consists of the last nine digits of the NSN (e. $\frac{5305-01-574-1467}{\text{NSN}}$
NIIN)

When using this column to locate an item, ignore the first 4 digits of the NSN. However, the complete NSN should be used when ordering items by stock number.

(2) FIG. column. This column lists the number of the figure where the item is identified/located. The figures are in numerical order in Section II and Section III.

(3) ITEM column. The item number identifies the item associated with the figure listed in the adjacent FIG. column. This item is also identified by the NSN listed on the same line.

b. *PART NUMBER INDEX.* Part number in this index are listed by part number in ascending alphanumeric sequence (i.e., vertical arrangement of letter and number combination which places the first letter or digit of each group in or order A through Z, followed by the numbers 0 through 9 and each following letter or digit in like order).

(1) FSCM column. The Federal Supply Code for Manufacturer (FSCM) is a 5-digit numeric code used to identify the manufacturer, distributor, or Government agency, etc., that supplies the item.

(2) PART NUMBER column. Indicates the primary number used by the manufacturer (individual, firm, corporation, or Government activity), which controls the design and characteristics of the item by means of its engineering drawings, specifications standards, and inspection requirements to identify an item or range of items.

(3) STOCK NUMBER column. This column lists the NSN for the associated part number and manufacturer identified in the PART NUMBER and FSCM columns to the left.

(4) FIG. column. This column lists the number of the figure where the item is identified/located in Sections II and III.

(5) ITEM column. The item number is that number assigned to the item as it appears in the figure referenced in the adjacent figure number column.

c. *FIGURE AND ITEM NUMBER INDEX.*

(1) FIG. column. This column lists the number of the figure where the item is identified/located in Section II and III.

(2) ITEM column. The item number is that number assigned to the item as it appears in the figure referenced in the adjacent figure number column.

(3) STOCK NUMBER column. This column lists the NSN for the item.

(4) FSCM column. The Federal Supply Code for Manufacturer (FSCM) is a 5-digit numeric code used to identify the manufacturer, distributor, or Government agency, etc., that supplies the item.

(5) PART NUMBER column. Indicates the primary number used by the manufacturer (individual, firm, corporation, or Government activity), which controls the design and characteristics of the item by means of its engineering drawings, specifications standards, and inspection requirements to identify an item or range of items.

C-5. SPECIAL INFORMATION.

a. *Fabrication Instructions.* Bulk materials required to manufacture items are listed in the bulk material functional group of this RPSTL. Part numbers for bulk materials are also referenced in the description column of the line item entry for the item to be manufactured/fabricated. Detailed fabrication instructions for items source coded to be manufactured or fabricated are found in Appendix E.

b. *Assembly Instructions.* Detailed assembly instructions for items source coded to be assembled from component spare/repair parts are found in Chapter 2. Items that make up the assembly are listed immediately following the assembly item entry or reference is made to an applicable figure.

c. *Index Numbers.* Items which have the word BULK in the figure column will have an index number shown in the item number column. This index number is a cross-reference between the National Stock Number/Part Number index and the bulk material list in Section II.

C-6. HOW TO LOCATE REPAIR PARTS.a. *When National Stock Number or Part Number is Not Known:*

(1) First. Using the table of contents, determine the assembly group or subassembly group to which the item belongs. This is necessary since figures are prepared for assembly groups and subassembly groups, and listings are divided into the same groups.

(2) Second. Find the figure covering the assembly group or subassembly group to which the item belongs.

(3) Third. Identify the item on the figure and use the Figure and Item Number Index to find the NSN.

b. *When National Stock Number or Part Number is Known:*

(1) First. Using the index of National Stock Number or the Part Number Index, find the pertinent National Stock Number or Part Number. The NSN index is in National Item Identification Number (NIIN) sequence (see C-4.1 (1)). The part numbers in the Part Number index are listed in ascending alphanumeric sequence (see C-4b). other indexes cross-reference you to the illustration/figure and item number of the item you are looking for.

(2) Second. Turn to the figure and item number, verify that the item is the one you're looking for, then locate the item number in the repair parts list for the figure.

C-7. ABBREVIATIONS.

PN No part number.

C-6/(C-7 blank)

Section II. REPAIR PARTS LIST

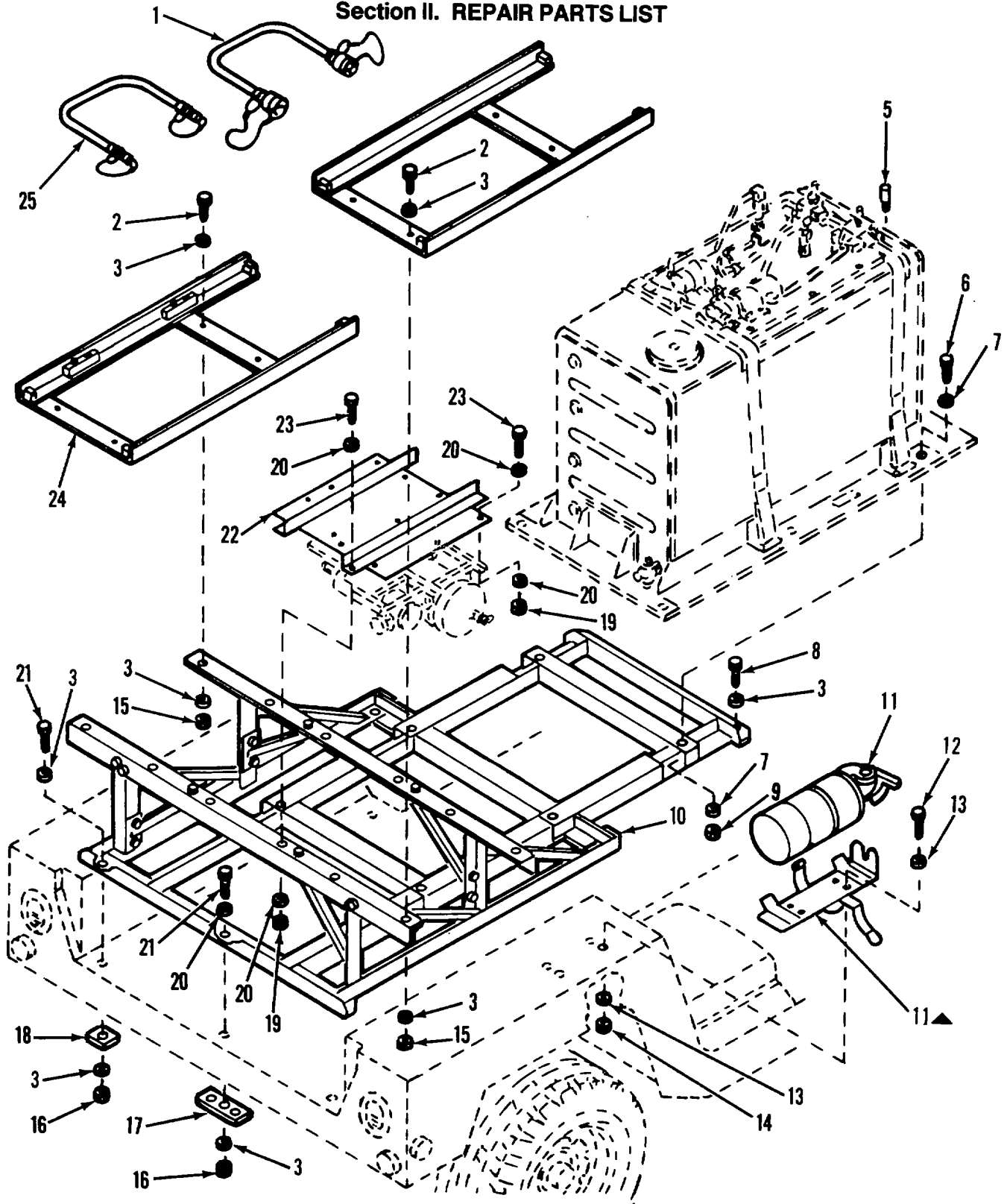

Figure C-1. M284 Smoke Generator Mounting Kit (Frame Assembly and Mounting Hardware).

Furnished with Basic Item

SECTION II.

TM 3-1040-280-20&P

(1)	(2)	(3)	(4)	(5)	(6)
ITEM NO	SMR CODE	FSCM	PART NUMBER	DESCRIPTION AND USABLE ON CODES(UOC)	QTY
				GROUP 00: M284 SMOKE GENERATOR MOUNTING KIT FIG C-1. M284 SMOKE GENERATOR MOUNTING KIT (FRAME ASSEMBLY AND MOUNTING HARDWARE) 31-15-2680	
1	AOOOO	81361	31-15-2665-20	HOSE ASSEMBLY OIL.....	2
2	PAOZZ	96906	MS90726-113	SCREW,CAP,HEXAGON H.....	8
3	PAOZZ	96906	MS27183-18	WASHER,FLAT.....	25
4	XDOOO	81361	31-15-2861-20	BRACKET, GENERATOR, R.....	1
5	PAOZZ	11243	2600618-1	VALVE, CHECK.....	1
6	PAOZZ	96906	MS90727-187	SCREW,CAP,HEXAGON H.....	6
7	PAOZZ	96906	MS27183-23	WASHER,FLAT.....	12
8	PAOZZ	96906	MS90728-114	SCREW,CAP,HEXAGON H.....	4
9	PAOZZ	96906	MS21045-L12	NUT, SELF-LOCKING, HE.....	6
10	XDOOO	81361	31-15-2857	FRAME, ASSEMBLY.....	11
11	PAOZZ	01317	CS4210-009AEG	EXTINGUISHER, FIRE, D.....	12
12	PAOZZ	96906	MS90727-8	SCREW,CAP,HEXAGON H.....	18
13	PAOZZ	96906	MS27183-9	WASHER,FLAT.....	16
14	PAOZZ	96906	MS21045-L4	NUT, SELF-LOCKING, HE.....	8
15	PAOZZ	96906	MS21045-L8	NUT, SELF-LOCKING, HE.....	8
16	PAOZZ	96906	MS51943-39	NUT, SELF-LOCKING, HE.....	3
17	PAOZZ	81361	31-15-2883	SPACER, PLATE.....	1
18	PAOZZ	81361	31-15-2884	SPACER, PLATE.....	2
19	PAOZZ	96906	MS21045-L6	NUT, SELF-LOCKING, HE.....	8
20	PAOZZ	96906	MS27183-14	WASHER,FLAT.....	9
21	PAOZZ	96906	MS90728-116	SCREW,CAP,HEXAGON H.....	3
22	XDOZZ	81361	31-15-2849	PLATE, MOUNTING.....	1
23	PAOZZ	96906	MS90726-67	SCREW,CAP,HEXAGON H.....	4
24	XDOOO	81361	31-15-2861-10	BRACKET, GENERATOR, L.....	1
25	AOOOO	81361	31-15-2665-10	HOSE ASSEMBLY AIR.....	2
				END OF FIGURE	

C-1-1

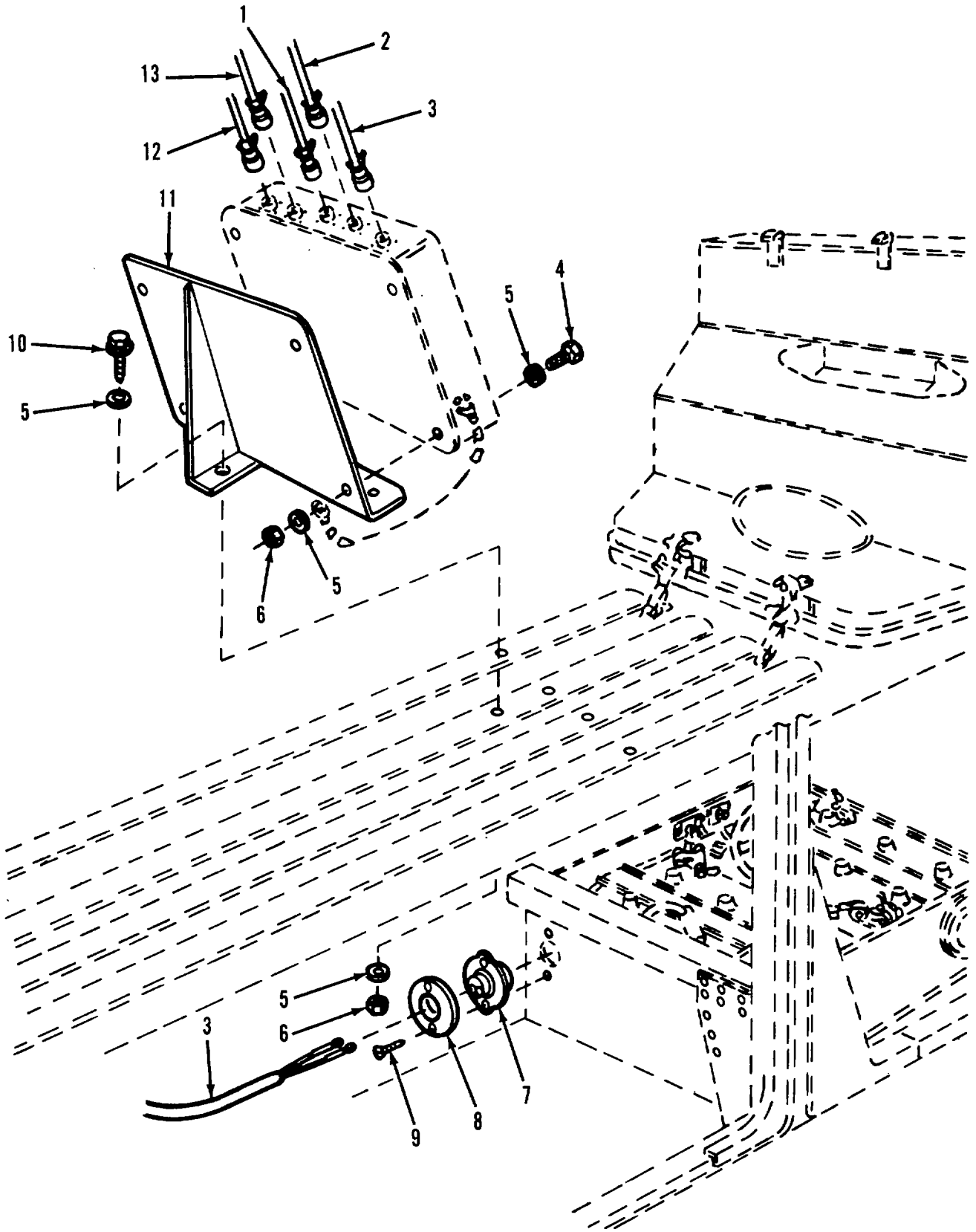

Figure C-2. M284 Smoke Generator Mounting Kit
(Control Panel Assembly Mount and Cable Assemblies).

SECTION II.

TM 3-1040-280-20&P

(1)	(2)	(3)	(4)	(5)	(6)
ITEM NO	SMR CODE	FSCM	PART NUMBER	DESCRIPTION AND USABLE ON CODES(UOC)	QTY
				GROUP 00: M284 SMOKE GENERATOR MOUNTING KIT FIG C-2. M284 SMOKE GENERATOR MOUNTING KIT (CONTROL PANEL ASSEMBLY MOUNT AND ELECTRICAL CABLE ASSEMBLIES) 31-15-2680	
1	PAOZZ	81361	31-15-2666-20	CABLE ASSEMBLY, POWE.....	1
2	PAOZZ	81361	31-15-2666-10	CABLE ASSEMBLY, POWE.....	1
3	PAOZZ	81361	31-15-2669	CABLE ASSEMBLY, POWE.....	1
4	PAOZZ	96906	MS90725-60	SCREW,CAP,HEXAGON H.....	4
5	PAOZZ	96906	MS27183-14	WASHER,FLAT.....	18
6	PAOZZ	96906	MS51922-17	NUT, SELF-LOCKING, HE.....	9
7	PAOZZ	81361	31-15-2869	GROMMET, NONMETALLIC.....	1
8	PAOZZ	19207	7703467	RETAINER, VEHICULAR.....	1
9	PAOZZ	96906	MS51851-106	SCREW, TAPPING, THREA.....	2
10	PAOZZ	96906	MS90728-66	SCREW,CAP,HEXAGON H.....	5
11	XDOZZ	81361	31-15-2827	BRACKET, MOUNTING.....	1
12	PAOZZ	81361	31-15-2668	CABLE ASSEMBLY, POWE.....	1
13	PAOZZ	81361	31-15-2667	CABLE ASSEMBLY, POWE.....	1

END OF FIGURE

C-2-1

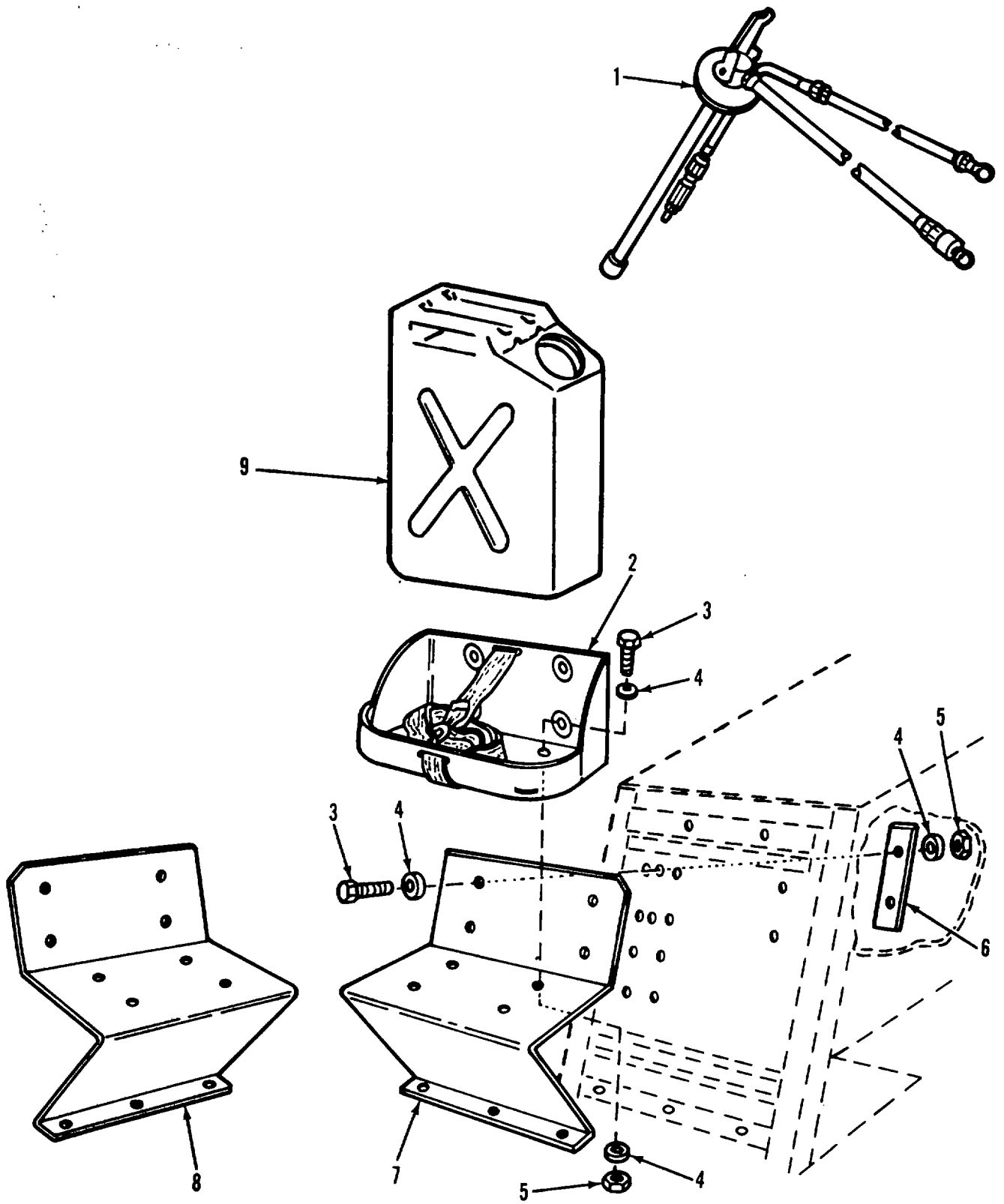

Figure C-3. M284 Smoke Generator Mounting Kit (Fuel Tank Mount and Fuel Lid Assembly).

SECTION II.

TM 3-1040-280-20&P

(1)	(2)	(3)	(4)	(5)	(6)
ITEM NO	SMR CODE	FSCM	PART NUMBER	DESCRIPTION AND USABLE ON CODES(UOC)	QTY
				GROUP 00: M284 SMOKE GENERATOR MOUNTING KIT FIG C-3. M284 SMOKE GENERATOR MOUNTING KIT (FUEL TANK MOUNT AND FUEL LID ASSEMBLY) 31-15-2680	
1	PAOOO	81361	31-15-2671	LID, FUEL ASSEMBLY.....	2
2	PAOZZ	07860	C21452	BRACKET ASSEMBLY, LI.....	2
3	PAOZZ	96906	MS90726-61	SCREW,CAP,HEXAGON H.....	22
4	PAOZZ	96906	MS27183-14	WASHER,FLAT.....	44
5	PAOZZ	96906	MS21045-L6	NUT, SELF-LOCKING, HE.....	22
6	XDOZZ	81361	31-15-2833	DOUBLER, BASE PLATE.....	4
7	XDOZZ	81361	31-15-2832-10	BASE PLATE, LEFT.....	1
8	XDOZZ	81361	31-15-2832-20	BASE PLATE, RIGHT.....	1
9	PAOZZ	80372	42-D-1280	CAN, GASOLINE, MILITA.....	2

END OF FIGURE

C-3-1

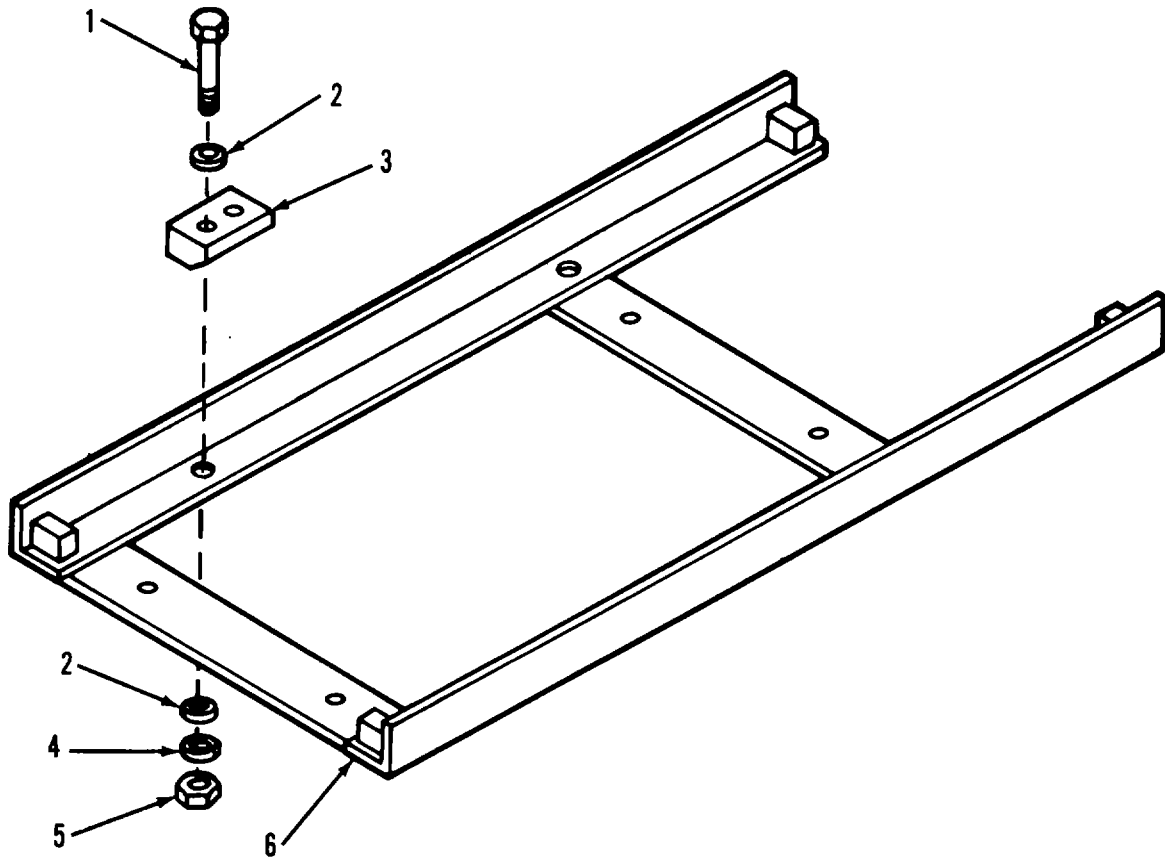

Figure C-4. Generator Bracket Assembly (Left or Right).

(1) ITEM NO	(2) SMR CODE	(3) FSCM	(4) PART NUMBER	(5) DESCRIPTION AND USABLE ON CODES(UOC)	(6) QTY
GROUP 01 & 02: GENERATOR BRACKET ASSEMBLY (LEFT OR RIGHT) FIG C-4. GENERATOR BRACKET ASSEMBLY (LEFT OR RIGHT) 31-15-2681-10 OR 31-15-2681-20					
1	PAOZZ	96906	MS90728-70	SCREW,CAP,HEXAGON H.....	2
2	PAOZZ	96906	MS27183-14	WASHER,FLAT.....	4
3	PAOZZ	19207	12313768	CONNECTING LINK, RIG	2
4	PAOZZ	96906	MS35338-46	WASHER,LOCK.....	2
5	PAOZZ	96906	MS51967-8	NUT,PLAIN,HEXAGON-.....	2
6	XAOZZ	81361	NPN	BRACKET, GENERATOR, L.....	1
6	XAOZZ	81361	NPN	BRACKET, GENERATOR, R.....	1
END OF FIGURE					

C-4-1/(C-4-2 blank)

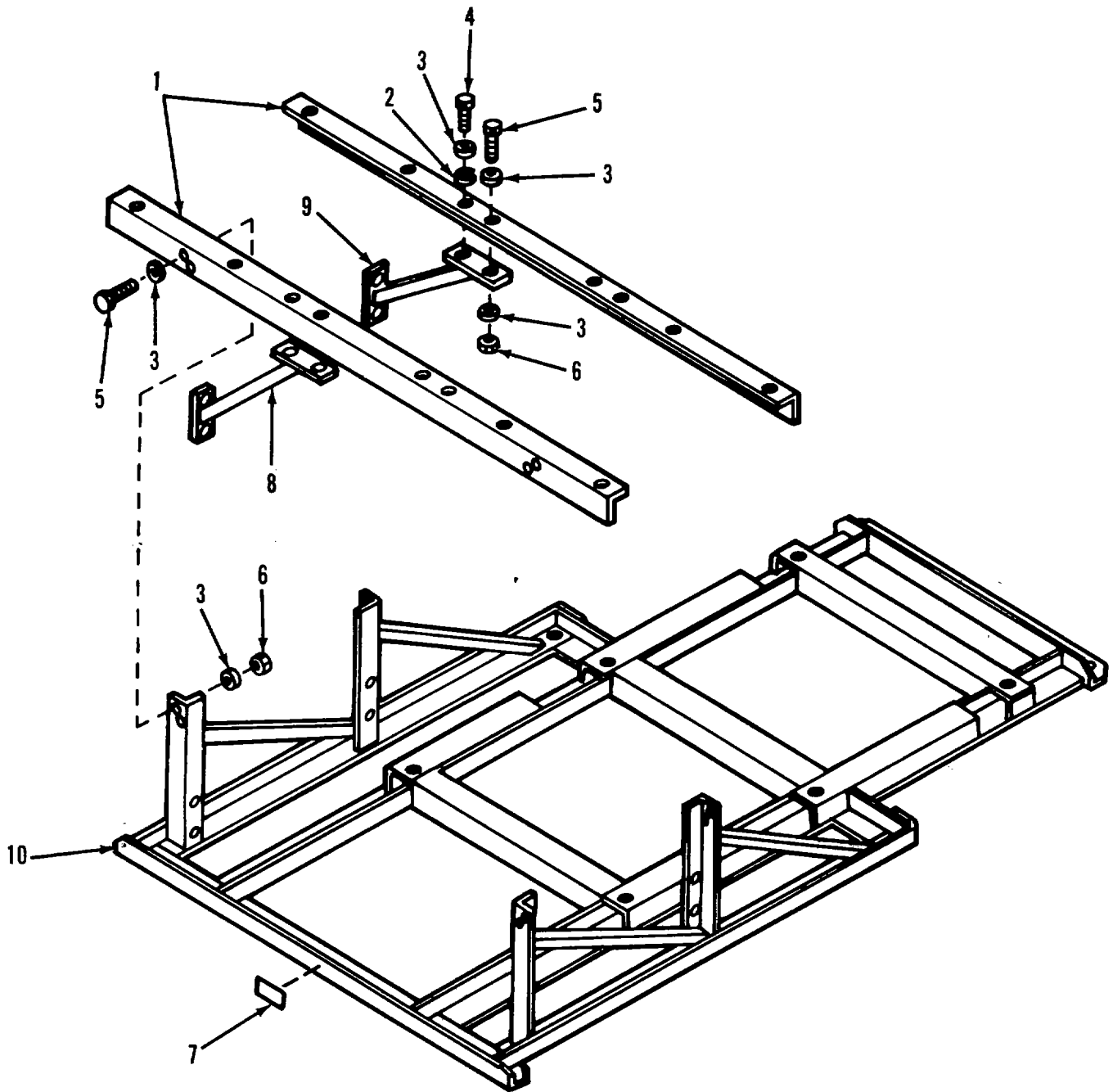

Figure C-5. Frame Assembly.

SECTION II TM3-1040-280-20&P

(1)	(2)	(3)	(4)	(5)	(6)
ITEM NO	SMR CODE	FSCM	PART NUMBER	DESCRIPTION AND USABLE ON CODES(UOC)	QTY
				GROUP 03: FRAME ASSEMBLY	
				FIG C-5. FRAME ASSEMBLY	
				31-15-2857	
1	XDOZZ	81361	31-15-2842	ANGLE,GENERATOR	2
2	PAOZZ	96906	MS35338-47	WASHER,LOCK	2
3	PAOZZ	96906	MS27183-16	WASHER,FLAT.....	62
4	PAOZZ	96906	MS90727-87	SCREW,CAP,HEXAGON H.....	30
5	PAOZZ	96906	MS90727-85	SCREW,CAP,HEXAGON H	2
6	PAOZZ	96906	MS21045-L7	NUT,SELF-LOCKING,HE	30
7	XDOZZ	81361	31-15 -2881	ID PLATE	1
8	XDOZZ	81361	31-15-2847	LEG,SUPPORT RAIL	2
9	XDOZZ	81361	31-15-2848	LEG,SUPPORT RAIL	2
10	XAOZZ	81361	NPN	FRAME WELDMENT.....	1

END OF FIGURE

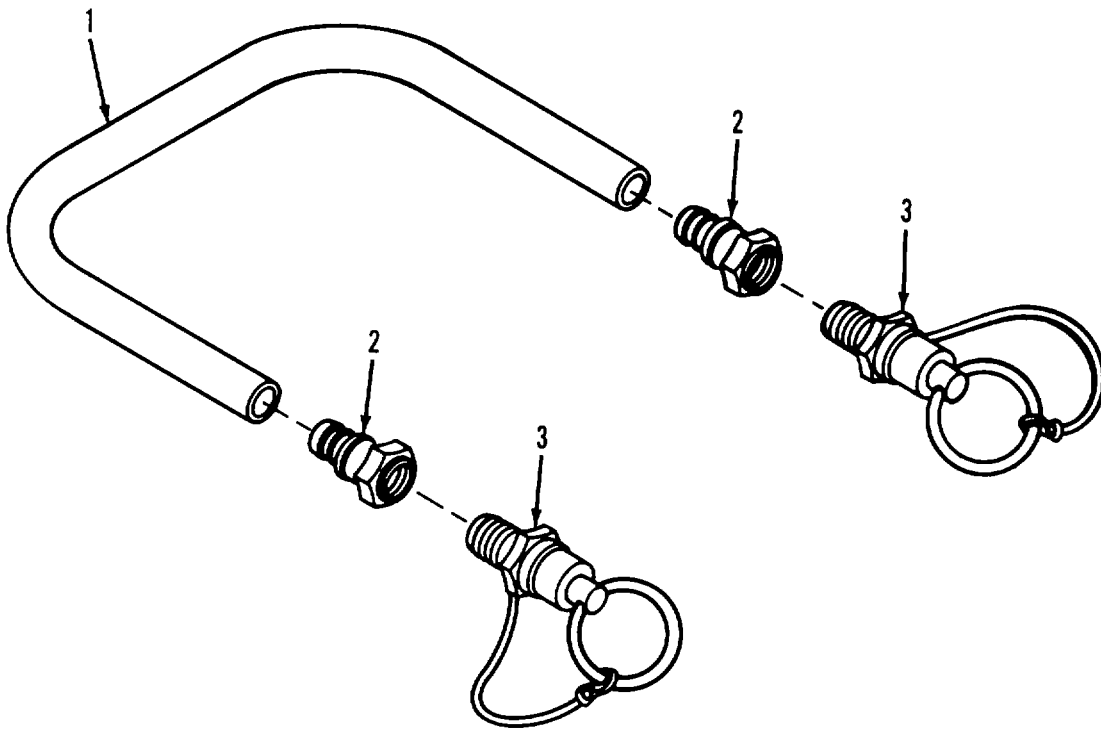

Figure C-6. Air Hose Assembly.

(1) ITEM NO	(2) SMR CODE	(3) FSCM	(4) PART NUMBER	(5) DESCRIPTION AND USABLE ON CODES(UOC)	(6) QTY
GROUP 04 & 0401: AIR HOSE ASSEMBLY AND HOSE ASSEMBLY FIG C-6. AIR HOSE ASSEMBLY 31-15-2665-10 AND 31-15-2664-10					
1	MOOZZ	81361	31-15-2664-10	HOSE, NONMETALLIC, MAKE FROM HOSE,.....	1
2	PAOZZ	01276	4797-8B	ADAPTER,STRAIGHT,TU	2
3	PAOZZ	19207	12350320-2	COUPLING HALF,QUICK	2
END OF FIGURE					

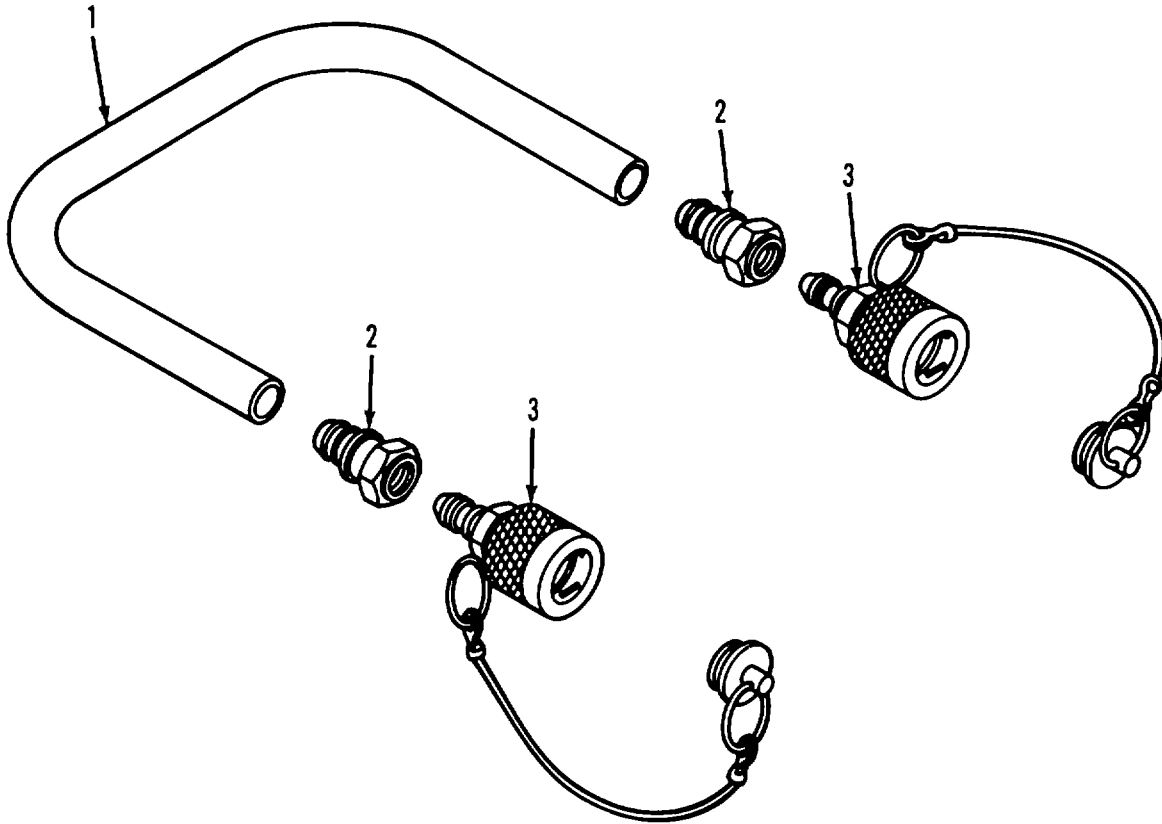

Figure C-7. Oil Hose Assembly.

(1) ITEM NO	(2) SMR CODE	(3) FSCM	(4) PART NUMBER	(5) DESCRIPTION AND USABLE ON CODES(UOC)	(6) QTY
				GROUP 05 & 0501: OIL HOSE ASSEMBLY AND HOSE ASSEMBLY FIG C-7. OIL HOSE ASSEMBLY 31-15-2665-20 AND 31-15-2664-10	
1	MOOZZ	81361	31-15-2664-10	HOSE, NONMETALLIC MAKE FROM HOSE,.....	1
2	PAOZZ	01276	4797-8B	ADAPTER, STRAIGHT, TU	2
3	PAOZZ	19207	12350320-1	COUPLING HALF, QUICK	2
				END OF FIGURE	

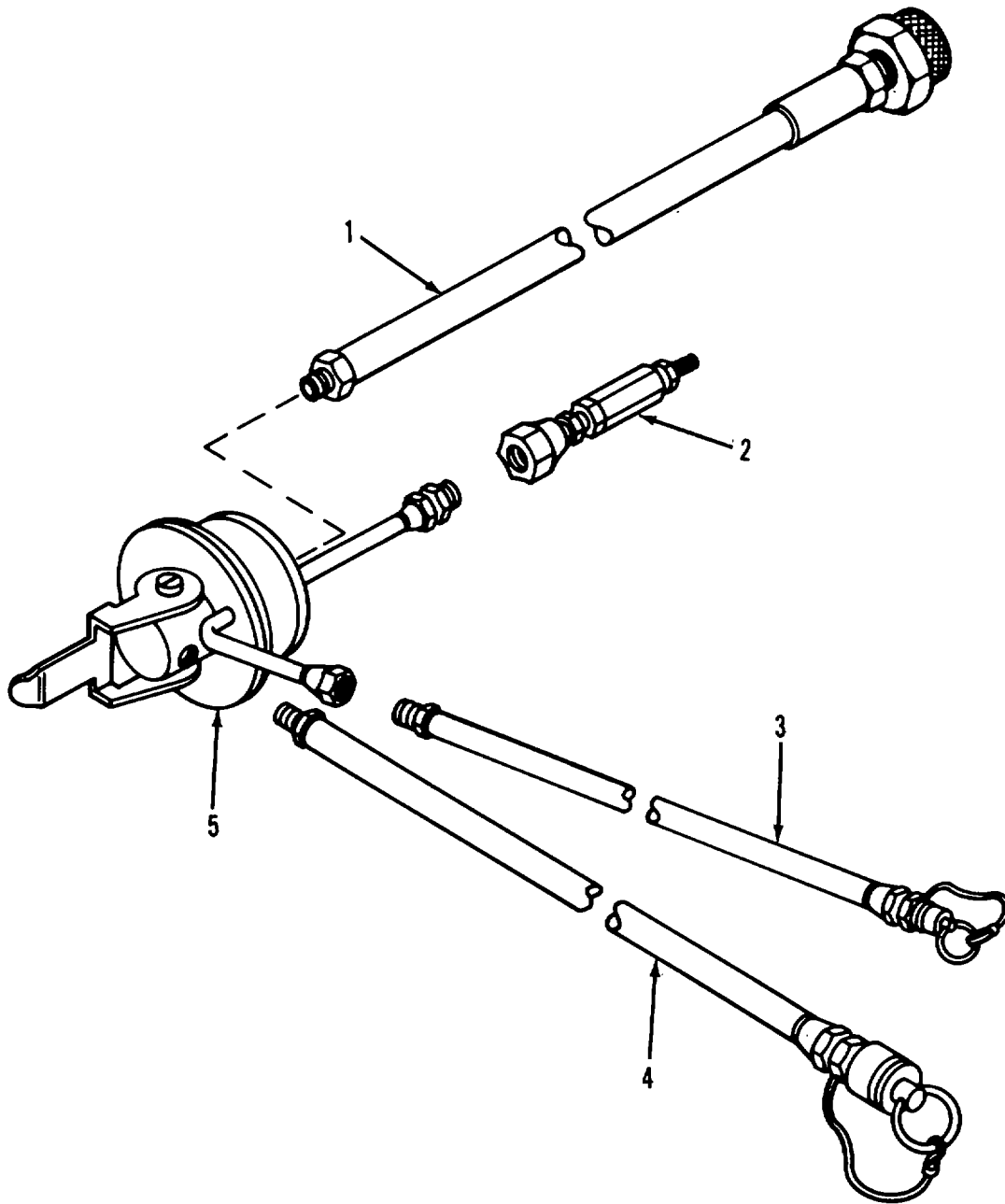

Figure C-8. Fuel Lid Assembly.

SECTION II TM3-1040-280-20&P

(1)	(2)	(3)	(4)	(5)	(6)
ITEM NO	SMR CODE	FSCM	PART NUMBER	DESCRIPTION AND USABLE ON CODES(UOC)	QTY
				GROUP 06: FUEL LID ASSEMBLY FIG C-8. FUEL LID ASSEMBLY 31-15-2671	
1	AOOOO	81361	D31-15-2672	HOSE ASSEMBLY	1
2	XAOZZ	81361	C31-15-2684	VALVE,CHECK	1
3	AOOOO	81361	D31-15-2673-20	HOSE ASSEMBLY	1
4	AOOOO	81361	D31-15-2673-10	HOSE ASSEMBLY	1
5	XAOZZ	81361	31-15-2675	LID, FUEL ADAPTER	1

END OF FIGURE

C-8-1/(C-8-2 blank)

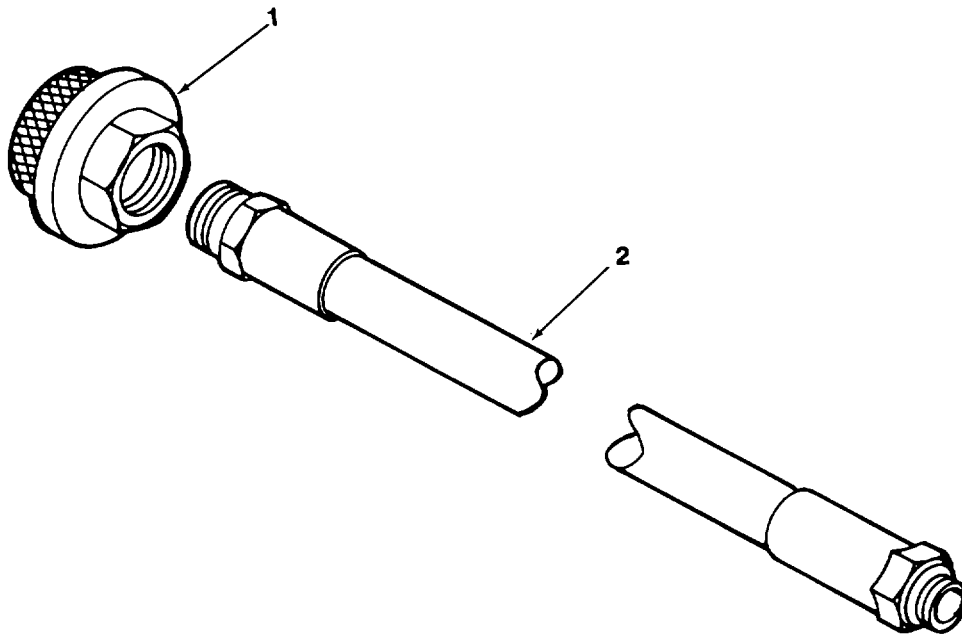

Figure C-9. Fuel Hose Assembly.

(1) ITEM NO	(2) SMR CODE	(3) FSCM	(4) PART NUMBER	(5) DESCRIPTION AND USABLE ON CODES(UOC)	(6) QTY
GROUP 0601: FUEL HOSE ASSEMBLY: FIG C-9. FUEL HOSE ASSEMBLY 31-15-2672					
1	PAOZZ	55524	M-3-100F	STRAINER,SUCTION.....	1
2	PAOZZ	19207	12354800	HOSE, METALLIC	1
END OF FIGURE					

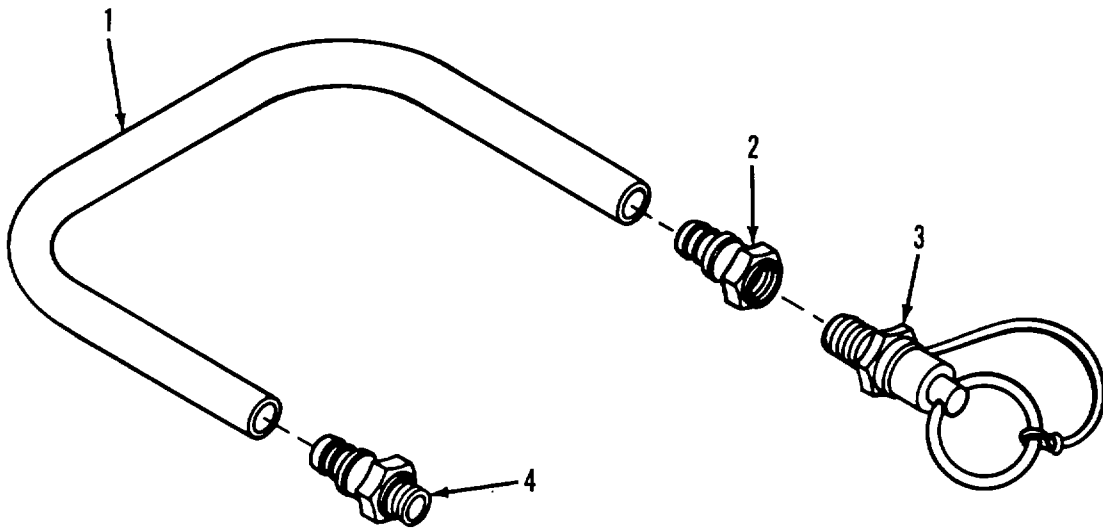

Figure C-10. Fuel Return Hose Assembly.

(1) ITEM NO	(2) SMR CODE	(3) FSCM	(4) PART NUMBER	(5) DESCRIPTION AND USABLE ON CODE S(UOC)	(6) QTY
GROUP 0602 & 060201: FUEL RETURN HOSE ASSEMBLY AND HOSE ASSEMBLY FIG C-10. FUEL RETURN HOSE ASSEMBLY 31-15-2673-20 AND 31-15-2664-30					
1	MOOZZ	81361	31-15-2664-30	HOSE, NONMETALLIC, MAKE FROM HOSE,..... P/N 483666/NSN 4720-00-913-5910	1
2	PAOZZ	98441	30682-4-4B	ADAPTER,STRAIGHT,TU	1
3	PAOZZ	19207	12350335-2	COUPLING ASSEMBLY,Q	1
4	PAOZZ	01276	4742-4B	ADAPTER,STRAIGHT,P	1
END OF FIGURE					

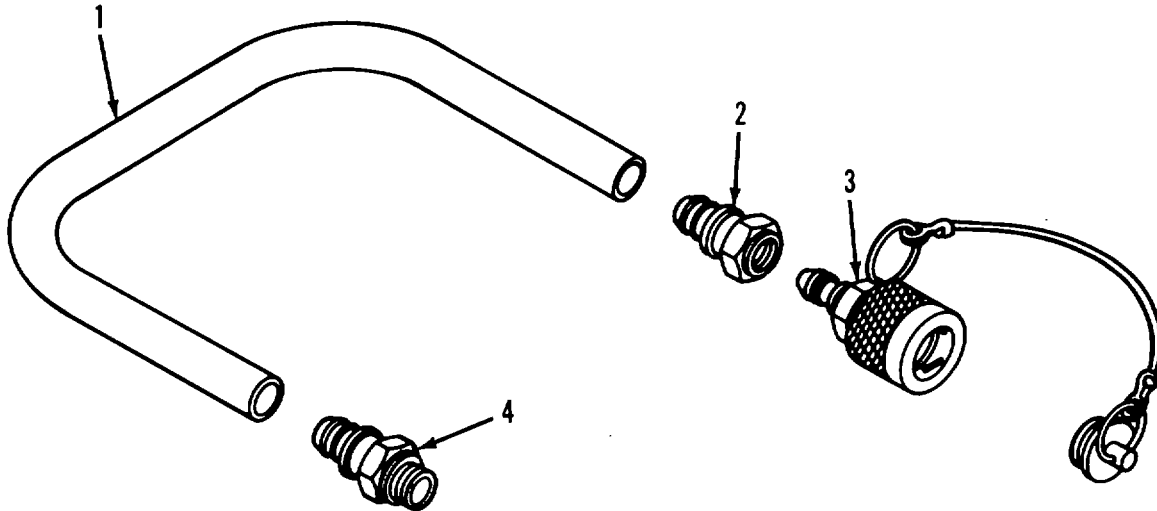

Figure C-11. Fuel Supply Hose Assembly.

(1) ITEM NO	(2) SMR CODE	(3) FSCM	(4) PART NUMBER	(5) DESCRIPTION AND USABLE ON CODES(UOC)	(6) QTY
GROUP 0603 & 060301: FUEL SUPPLY HOSE ASSEMBLY AND HOSE ASSEMBLY FIG C-11. FUEL SUPPLY HOSE ASSEMBLY 31-15-2673-10 AND 31-15-2664-20					
1	MOOZZ	81361	31-15-2664-20	HOSE, NONMETALLIC, MAKE FROM HOSE,	1
2	PAOZZ	01276	4741-6B	P/N 2565-6/NSN 4892-00-278-4892	1
3	PAOZZ	19207	12350328-1	ADAPTER, STRAIGHT, TU	1
4	PAOZZ	01276	4738-4-6B	COUPLING ASSEMBLY, Q	1
				ADAPTER, STRAIGHT, PI	1
END OF FIGURE					

SECTION II TM3-1040-280-20&P

(1) ITEM NO	(2) SMR CODE	(3) FSCM	(4) PART NUMBER	(5) DESCRIPTION AND USABLE ON CODES(UOC)	(6) QTY
				GROUP 99: BULK MATERIALS FIG BULK	
1	PAOZZ	01276	2565-8	HOSE, NONMETALLIC 1/2 NOM ID	2
2	PAOZZ	00624	2565-6	HOSE, NONMETALLIC 3/8 NOM ID	2
3	PAOZZ	02280	483666	HOSE, NONMETALLIC 1/4 NOM ID	1
				END OF FIGURE	

Section III. SPECIAL TOOLS LIST

Not Applicable

BULK-1

**CROSS-REFERENCE INDEXES
NATIONAL STOCK NUMBER INDEX**

STOCK NUMBER	FIG	ITEM	STOCK NUMBER	FIG	ITEM
5305-00-068-0515	C-1	12	6150-01-253-6134	C-2	12
5305-00-071-2070	C-1	8	5325-01-253-6164	C-2	7
5305-00-071-2072	C-1	21	6150-01-253-6165	C-2	3
5310-00-080-6004	C-1	20	4730-01-258-3841	C-10	3
	C-2	5	5365-01-258-7939	C-1	18
	C-3	4	5365-01-258-7940	C-1	17
	C-4	2	4720-01-259-4427	C-9	2
5310-00-087-4652	C-2	6	4730-01-259-4429	C-11	3
*2590-00-150-7684	C-2	8	6150-01-278-1166	C-2	2
5310-00-209-0965	C-5	2			
7240-00-222-3088	C-3	9			
5305-00-269-2804	C-3	3			
5305-00-269-2811	C-1	23			
5305-00-269-3211	C-2	4			
4720-00-278-4892	BULK	2			
2590-00-473-6331	C-3	2			
5310-00-488-3889	C-1	16			
*4730-00-542-2807	C-6	2			
	C-7	2			
4730-00-555-1152	C-10	2			
4730-00-588-2614	C-11	2			
5310-00-637-9541	C-4	4			
4720-00-670-6037	BULK	1			
5305-00-709-8517	C-5	5			
5305-00-709-8523	C-5	4			
5305-00-725-4183	C-1	2			
5310-00-732-0558	C-4	5			
4210-00-775-0127	C-1	11			
5305-00-782-9489	C-2	10			
5310-00-809-4085	C-5	3			
5310-00-809-5998	C-1	3			
5310-00-809-8533	C-1	7			
5310-00-823-8804	C-1	13			
5305-00-846-5703	C-4	1			
5310-00-857-4948	C-1	19			
	C-3	5			
5310-00-857-5557	C-1	14			
5310-00-857-5562	C-1	15			
5310-00-857-5975	C-1	9			
5310-00-857-5976	C-5	6			
4720-00-913-5910	BULK	3			
5305-00-916-2345	C-1	6			
4820-01-046-6529	C-1	5			
5305-01-090-3012	C-2	9			
3040-01-248-8921	C-4	3			
4730-01-249-0420	C-6	3			
4730-01-249-0421	C-7	3			
1040-01-253-6087	C-3	1			
6150-01-253-6132	C-2	1			
6150-01-253-6133	C-2	13			
*4730-00-540-0720	C-10	4			
*4730-00-088-7242	C-11	4			

CROSS-REFERENCE INDEXES

PART NUMBER INDEX

FSCM	PART NUMBER	STOCK NUMBER	FIG.	ITEM
01317	CS4210-009AEG	4210-00-775-0127	C-1	11
07860	C21452	2590-00-473-6331	C-3	2
81361	C31-15-2684		C-8	2
81361	D31-15-2672		C-8	1
81361	D31-15-2673-10		C-8	4
81361	D31-15-2673-20		C-8	3
55524	M-3-100F		C-9	1
96906	MS21045-112	5310-00-857-5975	C-1	9
96906	MS21045-14	5310-00-857-5557	C-1	14
96906	MS21045-16	5310-00-857-4948	C-1	19
			C-3	5
96906	MS21045-17	5310-00-857-5976	C-5	6
96906	MS21045-18	5310-00-857-5562	C-1	15
96906	MS27183-14	5310-00-080-6004	C-1	20
			C-2	5
			C-3	4
			C-4	2
96906	MS27183-16	5310-00-809-4085	C-5	3
96906	MS27183-18	5310-00-809-5998	C-1	3
96906	MS27183-23	5310-00-809-8533	C-1	7
96906	MS27183-9	5310-00-823-8804	C-1	13
96906	MS35338-46	5310-00-637-9541	C-4	4
96906	MS35338-47	5310-00-209-0965	C-5	2
96906	MS51851-106	5305-01-090-3012	C-2	9
96906	MS51922-17	5310-00-087-4652	C-2	6
96906	MS51943-39	5310-00-488-3889	C-1	16
96906	MS51967-8	5310-00-732-0558	C-4	5
96906	MS90725-60	5305-00-269-3211	C-2	4
96906	MS90726-113	5305-00-725-4183	C-1	2
96906	MS90726-61	5305-00-269-2804	C-3	3
96906	MS90726-67	5305-00-269-2811	C-1	23
96906	MS90727-187	5305-00-916-2345	C-1	6
96906	MS90727-8	5305-00-068-0515	C-1	12
96906	MS90727-85	5305-00-709-8517	C-5	5
96906	MS90727-87	5305-00-709-8523	C-5	4
96906	MS90728-114	5305-00-071-2070	C-1	8
96906	MS90728-116	5305-00-071-2072	C-1	21
96906	MS90728-66	5305-00-782-9489	C-2	10
96906	MS90728-70	5305-00-846-5703	C-4	1
81361	NPN		C-4	6
			C-4	6
			C-5	10
19207	12313768	3040-01-248-8921	C-4	3
19207	12350320-1	4730-01-249-0421	C-7	3
19207	12350320-2	4730-01-249-0420	C-6	3
19207	12350328-1	4730-01-259-4429	C-11	3
19207	12350335-2	4730-01-258-3841	C-10	3
19207	12354800	4720-01-259-4427	C-9	2
00624	2565-6	4720-00-278-4892	BULK	2
01276	2565-8	4720-00-670-6037	BULK	1
11243	2600618-1	4820-01-046-6529	C-1	5

CROSS-REFERENCE INDEXES

PART NUMBER INDEX

FSCM	PART NUMBER	STOCK NUMBER	FIG.	ITEM
81361	31-15 -2881		C-5	7
81361	31-15-2664-10		C-6	1
			C-7	1
81361	31-15-2664-20		C-11	1
81361	31-15-2664-30		C-10	1
81361	31-15-2665-10		C-1	25
81361	31-15-2665-20		C-1	1
81361	31-15-2666-10	6150-01-278-1166	C-2	2
81361	31-15-2666-20	6150-01-253-6132	C-2	1
81361	31-15-2667	6150-01-253-6133	C-2	13
81361	31-15-2668	6150-01-253-6134	C-2	12
81361	31-15-2669	6150-01-253-6165	C-2	3
81361	31-15-2671	1040-01-253-6087	C-3	1
81361	31-15-2675		C-8	5
81361	31-15-2827		C-2	11
81361	31-15-2832-10		C-3	7
81361	31-15-2832-20		C-3	8
81361	31-15-2833		C-3	6
81361	31-15-2842		C-5	1
81361	31-15-2847		C-5	8
81361	31-15-2848		C-5	9
81361	31-15-2849		C-1	22
81361	31-15-2857		C-1	10
81361	31-15-2861-10		C-1	24
81361	31-15-2861-20		C-1	4
81361	31-15-2869	5325-01-253-6164	C-2	7
81361	31-15-2883	5365-01-258-7940	C-1	17
81361	31-15-2884	5365-01-258-7939	C-1	18
80372	42-D-1280	7240-00-222-3088	C-3	9
01276	4738-4-6B	4730-00-088-7242	C-11	4
01276	4741-6B	4730-00-588-2614	C-11	2
01276	4742-4B	4730-00-540-0720	C-10	4
98441	30682-4-4B	4730-00-555-1152	C-10	2
01276	4797-8B	4730-00-542-2807	C-6	2
			C-7	2
02280	483666	4720-00-913-5910	BU1K	3
19207	7703467	2590-00-150-7684	C-2	8

**CROSS-REFERENCE INDEXES
FIGURE AND ITEM NUMBER INDEX**

FIG.	ITEM	STOCK NUMBER	FSCM	PART NUMBER
BULK	1	4720-00-670-6037	01276	2565-8
BULK	2	4720-00-278-4892	00624	2565-6
BULK	3	4720-00-913-5910	02280	483666
C-1	1		81361	31-15-2665-20
C-1	2	5305-00-725-4183	96906	MS90726-113
C-1	3	5310-00-809-5998	96906	MS27183-18
C-1	4		81361	31-15-2861-20
C-1	5	4820-01-046-6529	11243	2600618-1
C-1	6	5305-00-916-2345	96906	MS90727-187
C-1	7	5310-00-809-8533	96906	MS27183-23
C-1	8	5305-00-071-2070	96906	MS90728-114
C-1	9	5310-00-857-5975	96906	MS21045-L12
C-1	10		81361	31-15-2857
C-1	11	4210-00-775-0127	01317	CS4210-009AEG
C-1	12	5305-00-068-0515	96906	MS90727-8
C-1	13	5310-00-823-8804	96906	MS27183-9
C-1	14	5310-00-857-5557	96906	MS21045-L4
C-1	15	5310-00-857-5562	96906	MS21045-L8
C-1	16	5310-00-488-3889	96906	MS51943-39
C-1	17	5365-01-258-7940	81361	31-15-2883
C-1	18	5365-01-258-7939	81361	31-15-2884
C-1	19	5310-00-857-4948	96906	MS21045-L6
C-1	20	5310-00-080-6004	96906	MS27183-14
C-1	21	5305-00-071-2072	96906	MS90728-116
C-1	22		81361	31-15-2849
C-1	23	5305-00-269-2811	96906	MS90726-67
C-1	24		81361	31-15-2861-10
C-1	25		81361	31-15-2665-10
C-2	1	6150-01-253-6132	81361	31-15-2666-20
C-2	2	6150-01-278-1166	81361	31-15-2666-10
C-2	3	6150-01-253-6165	81361	31-15-2669
C-2	4	5305-00-269-3211	96906	MS90725-60
C-2	5	5310-00-080-6004	96906	MS27183-14
C-2	6	5310-00-087-4652	96906	MS51922-17
C-2	7	5325-01-253-6164	81361	31-15-2869
C-2	8	2590-00-150-7684	19207	7703467
C-2	9	5305-01-090-3012	96906	MS51851-106
C-2	10	5305-00-782-9489	96906	MS90728-66
C-2	11		81361	31-15-2827
C-2	12	6150-01-253-6134	81361	31-15-2668
C-2	13	6150-01-253-6133	81361	31-15-2667
C-3	1	1040-01-253-6087	81361	31-15-2671
C-3	2	2590-00-473-6331	07860	C21452
C-3	3	5305-00-269-2804	96906	MS90726-61
C-3	4	5310-00-080-6004	96906	MS27183-14
C-3	5	5310-00-857-4948	96906	MS21045-L6
C-3	6		81361	31-15-2833
C-3	7		81361	31-15-2832-10
C-3	8		81361	31-15-2832-20
C-3	9	7240-00-222-3088	80372	42-D-1280
C-4	1	5305-00-846-5703	96906	MS90728-70

**CROSS-REFERENCE INDEXES
FIGURE AND ITEM NUMBER INDEX**

FIG.	ITEM	STOCK NUMBER	FSCM	PART NUMBER
C-4	2	5310-00-080-6004	96906	MS27183-14
C-4	3	3040-01-248-8921	19207	12313768
C-4	4	5310-00-637-9541	96906	MS35338-46
C-4	5	5310-00-732-0558	96906	MS51967-8
C-4	6		81361	NPN
C-4	6		81361	NPN
C-5	1		81361	31-15-2842
C-5	2	5310-00-209-0965	96906	MS35338-47
C-5	3	5310-00-809-4085	96906	MS27183-16
C-5	4	5305-00-709-8523	96906	MS90727-87
C-5	5	5305-00-709-8517	96906	MS90727-85
C-5	6	5310-00-857-5976	96906	MS21045-L7
C-5	7		81361	31-15-2881
C-5	8		81361	31-15-2847
C-5	9		81361	31-15-2848
C-5	10		81361	NPN
C-6	1		81361	31-15-2664-10
C-6	2	4730-00-542-2807	01276	4797-8B
C-6	3	4730-01-249-0420	19207	12350320-2
C-7	1		81361	31-15-2664-10
C-7	2	4730-00-542-2807	01276	4797-8B
C-7	3	4730-01-249-0421	19207	12350320-1
C-8	1		81361	D31-15-2672
C-8	2		81361	C31-15-2684
C-8	3		81361	D31-15-2673-20
C-8	4		81361	D31-15-2673-10
C-8	5		81361	31-15-2675
C-9	1		55524	M-3-100F
C-9	2	4720-01-259-4427	19207	12354800
C-10	1		81361	31-15-2664-30
C-10	2	4730-00-555-1152	98441	30682-4-4B
C-10	3	4730-01-258-3841	19207	12350335-2
C-10	4	4730-00-540-0720	01276	4742-4B
C-11	1		81361	31-15-2664-20
C-11	2	4730-00-588-2614	01276	4741-6B
C-11	3	4730-01-259-4429	19207	12350328-1
C-11	4	4730-00-088-7242	01276	4738-4-6B

C-I-5/(C-I-6 blank)

**APPENDIX D
EXPENDABLE/DURABLE SUPPLIES AND MATERIALS LIST**

Section I. INTRODUCTION

D-1. SCOPE. This appendix lists expendable/durable supplies and materials you will need to maintain the mounting kit. This listing is for informational purposes only and is not authority to requisition the listed items.

These items are authorized to you by CTA 50-970, Expendable/Durable Items (Except Medical, Class V, Repair Parts, and Heraldic Items), or CTA 8-100, Army Medical Department Expendable/Durable Items.

D-2. EXPLANATION OF COLUMNS.

a. Column (1) Item Number. This number is assigned to the entry in the listing and is referenced in the narrative instructions to identify the material (e.g., "Use polyurethane coating, item 7, app D").

b. Column (2) Level. This column identifies the lowest level of maintenance that requires the listed item.

O - Unit Maintenance

c. Column (3) National Stock Number. This is the National Stock Number assigned to the item; use it to request or requisition the item.

d. Column (4) Description. Indicates the Federal item name and, if required, a description to identify the item. The last line for each item indicates the Federal Supply Code for Manufacturer (FSCM) in parentheses followed by the part number.

e. Column (5) Unit of Measure (U/M). Indicates the measure used in performing the actual maintenance function. This measure is expressed by a two-character alphabetical abbreviation (e.g., ea, in., pr). If the unit of measure differs from the unit of issue, requisition the lowest unit of issue that will satisfy your requirements.

Section II. EXPENDABLE/DURABLE SUPPLIES

(1) Item Number	(2) Level	(3) National Stock Number	(4) Description	(5) U/M
1	O	8040-00-290-4301	Adhesive (02769) 2010832-1	QT
1A	O	4730-01-042-2960	Adapter, Straight Pipe (96906) MS51 503A8	EA
2	O	8020-00-721-9650	Brush, Paint (81348) H-B-451	EA
3	O	5350-00-174-1001	Cloth, Abrasive (58536) A-A-1 200	EA
4	O	6850-00-281-1985	Dry Cleaning Solvent (58536) A-A-711	GL
5	O	8010-01-193-0516	Epoxy Primer Coating Kit (81349) MIL-P-53022	KT
6	O	9330-00-003-6171	Plastic Strip (52152) SJ8561	FT

(1) Item Number	(2) Level	(3) National Stock Number	(4) Description	(5) U/M
7	O	8010-01-160-6741	Polyurethane Coating (81349) MIL-C-46168	KT
8	O	7920-00-205-1711	Rag, Wiping (58536) A-A-2522	LB
9	O	8030-00-849-0071	Sealing Compound (77247) FORMAGASKETNO2	OZ
10	O	5975-01-034-5871	Strap, Tie Down (96906) MS3367-7-0	EA

**APPENDIX E
ILLUSTRATED LIST OF MANUFACTURED ITEMS**

Section I. INTRODUCTION

E-1. This appendix includes complete instructions for making items authorized to be manufactured or fabricated at unit or intermediate direct support maintenance level.

E-2. A part number index in alphanumeric order cross-references the part number of the item to be manufactured to the figure which covers fabrication criteria.

E-3. All bulk materials needed for manufacture of an item are listed by national stock number and part number on the illustration.

INDEX

Item	Figure Number
Drain Hose	E-1
31-15-2664-10 (Air and Oil Hoses)	E-2
31-15-2672 (Fuel Hose)	E-3
31-15-2664-30 (Fuel Return Hose)	E-4
31-15-2664-20 (Fuel Supply Hose)	E-5

Section II. MANUFACTURED ITEMS

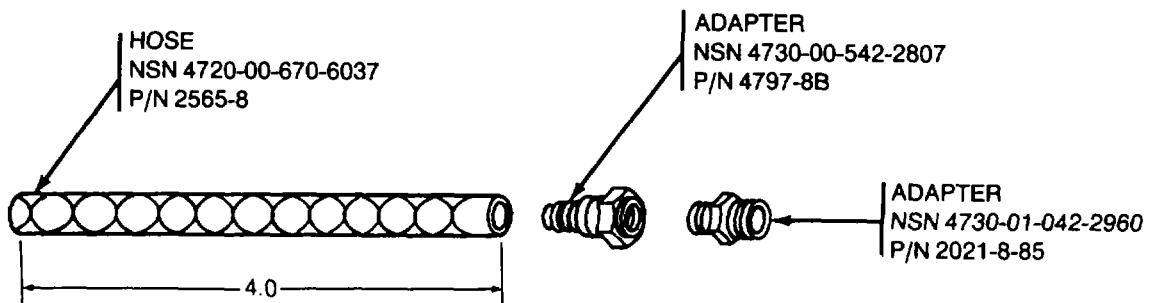

NOTE: DIMENSIONS ARE IN FEET

Figure E- 1. Drain Hose.

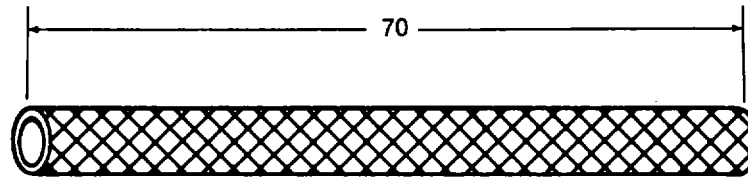

NOTES:

1. FABRICATE FROM 1/2 IN. ID NONMETALLIC HOSE (NSN 4720-00-670-6037, P/N 2565-8).
2. DIMENSIONS ARE IN INCHES.

Figure E-2. Air and Oil Hoses (31-15-2664-10)

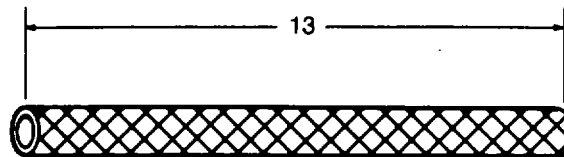

NOTES:

1. FABRICATE FROM 3/8 IN. ID NONMETALLIC HOSE (NSN 4720-00-278-4892, P/N 2565-6).
2. DIMENSIONS ARE IN INCHES.

Figure E-3. Fuel Hose (31-15-2672).

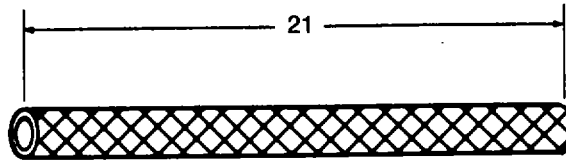

NOTES:

1. FABRICATE FROM 1/4 IN. ID NONMETALLIC HOSE (NSN 4720-00-913-5910, P/N 483666).
2. DIMENSIONS ARE IN INCHES.

Figure E-4. Fuel Return Hose 31-15-2664-30

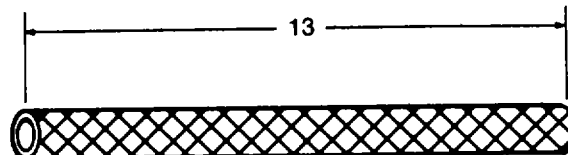

NOTES:

1. FABRICATE FROM 3/8 IN. ID NONMETALLIC HOSE (NSN 4720-00-278-4892, P/N 2565-6).
2. DIMENSIONS ARE IN INCHES.

Figure E-5. Fuel Supply Hose (31-15-2664-20).

By Order of the Secretary of the Army:

Official:

WILLIAM J. MEEHAN
Brigadier General, United States Army
The Adjutant General

CARL E. VUONO
General, United States Army
Chief of Staff

Distribution:

To be distributed in accordance with DA Form 12-28, requirements for TM 3-1040-280-20&P.

The Metric System and Equivalents

Linear Measure

1 centimeter = 10 millimeters = .39 inch
 1 decimeter = 10 centimeters = 3.94 inches
 1 meter = 10 decimeters = 39.37 inches
 1 dekameter = 10 meters = 32.8 feet
 1 hectometer = 10 dekameters = 328.08 feet
 1 kilometer = 10 hectometers = 3,280.8 feet

Weights

1 centigram = 10 milligrams = .15 grain
 1 decigram = 10 centigrams = 1.54 grains
 1 gram = 10 decigrams = .035 ounce
 1 decagram = 10 grams = .35 ounce
 1 hectogram = 10 decagrams = 3.52 ounces
 1 kilogram = 10 hectograms = 2.2 pounds
 1 quintal = 100 kilograms = 220.46 pounds
 1 metric ton = 10 quintals = 1.1 short tons

Liquid Measure

1 centiliter = 10 milliliters = .34 fl. ounce
 1 deciliter = 10 centiliters = 3.38 fl. ounces
 1 liter = 10 deciliters = 33.81 fl. ounces
 1 dekaliter = 10 liters = 2.64 gallons
 1 hectoliter = 10 dekaliters = 26.42 gallons
 1 kiloliter = 10 hectoliters = 264.18 gallons

Square Measure

1 sq. centimeter = 100 sq. millimeters = .155 sq. inch
 1 sq. decimeter = 100 sq. centimeters = 15.5 sq. inches
 1 sq. meter (centare) = 100 sq. decimeters = 10.76 sq. feet
 1 sq. dekameter (are) = 100 sq. meters = 1,076.4 sq. feet
 1 sq. hectometer (hectare) = 100 sq. dekameters = 2.47 acres
 1 sq. kilometer = 100 sq. hectometers = .386 sq. mile

Cubic Measure

1 cu. centimeter = 1000 cu. millimeters = .06 cu. inch
 1 cu. decimeter = 1000 cu. centimeters = 61.02 cu. inches
 1 cu. meter = 1000 cu. decimeters = 35.31 cu. feet

Approximate Conversion Factors

<i>To change</i>	<i>To</i>	<i>Multiply by</i>	<i>To change</i>	<i>To</i>	<i>Multiply by</i>
inches	centimeters	2.540	ounce-inches	Newton-meters	.007062
feet	meters	.305	centimeters	inches	.394
yards	meters	.914	meters	feet	3.280
miles	kilometers	1.609	meters	yards	1.094
square inches	square centimeters	6.451	kilometers	miles	.621
square feet	square meters	.093	square centimeters	square inches	.155
square yards	square meters	.836	square meters	square feet	10.764
square miles	square kilometers	2.590	square meters	square yards	1.196
acres	square hectometers	.405	square kilometers	square miles	.386
cubic feet	cubic meters	.028	square hectometers	acres	2.471
cubic yards	cubic meters	.765	cubic meters	cubic feet	35.315
fluid ounces	milliliters	29.573	cubic meters	cubic yards	1.308
pints	liters	.473	milliliters	fluid ounces	.034
quarts	liters	.946	liters	pints	2.113
gallons	liters	3.785	liters	quarts	1.057
ounces	grams	28.349	liters	gallons	.264
pounds	kilograms	.454	grams	ounces	.035
short tons	metric tons	.907	kilograms	pounds	2.205
pound-feet	Newton-meters	1.356	metric tons	short tons	1.102
pound-inches	Newton-meters	.11296			

Temperature (Exact)

°F	Fahrenheit temperature	5/9 (after subtracting 32)	Celsius temperature	°C
----	---------------------------	-------------------------------	------------------------	----

